

# Operator's Manual

## **X4™ 7300 / 7500** Trailer and Rail Refrigeration Units



62-11644-00  
Rev J







Operator's Manual  
**X4™ 7300 / 7500**  
Trailer and Rail Refrigeration Units

**Manual Revision History**  
**62-11644**

<b>Rev</b>	<b>Date</b>	<b>Description</b>
E		
F	4/20/2020	Updated with new logo and cover
G	9/30/2020	Updated section headers with section numbers; Section 24 - Fuses: Updated to reflect new APX
H	4/16/2021	Updated verbiage, sentence structure, phrasing
J	6/4/2021	Added Warranty section

## TABLE OF CONTENTS

1. INTRODUCTION.....	1
2. UNIT IDENTIFICATION .....	2
3. SAFETY .....	3
4. DISPLAY .....	5
5. STARTING UNIT.....	7
6. INSPECT MODE .....	9
7. INTELLISET .....	11
8. OPERATOR MESSAGES.....	13
9. PRETRIP.....	15
10. CHANGING SETPOINT .....	18
11. START/STOP OR CONTINUOUS OPERATION .....	19
12. DATA RECORDER / TRIP START .....	21
13. LANGUAGE SELECTION .....	25
14. UNIT DATA .....	26
15. ALARM LIST .....	29
16. VIEW HOUR METERS.....	30
17. STOPPING UNIT .....	31
18. EMERGENCY BYPASS MODE .....	32
19. PRETRIP INSPECTION.....	34
20. PRODUCT LOADING .....	36
21. RECOMMENDED TRANSPORT TEMPERTURES .....	37
22. GENERAL TROUBLESHOOTING .....	38
23. FUSES .....	40
24. UNIT MAINTENANCE.....	42
25. WARRANTY.....	46
26. EMERGENCY ROAD SERVICE .....	48



# 1. Introduction

This guide has been prepared for the operator of a Carrier Transicold X4™ 7300/7500 Trailer or Rail refrigeration unit with APX™ Control System. It contains basic instructions for the daily operation of the refrigeration unit as well as safety information, troubleshooting tips, and other information that will help you to deliver the load in the best possible condition. Please take the time to read the information contained in this booklet and refer to it whenever you have a question about the operation of this Carrier Transicold unit.

This refrigeration unit has been engineered to provide long, trouble-free performance when it is properly operated and maintained. The checks outlined in this guide will help to minimize over-the-road problems. In addition, a comprehensive maintenance program will help to ensure that the unit continues to operate reliably. Such a maintenance program will also help to control operating costs, increase the unit's working life, and improve performance.

This guide is intended as an introduction to this unit and to provide general assistance when needed. More comprehensive information can be found in the Operation and Service manual for this unit. This manual can be obtained from your Carrier Transicold dealer.

When having this unit serviced, be sure to specify genuine Carrier Transicold replacement parts for the highest quality and best reliability.

At Carrier Transicold, we are continually working to improve the products that we build for our customers. As a result, specifications may change without notice.

## 2. Unit Identification

Each unit is identified by a decal attached to the frame of the unit inside the roadside side door. This decal is on the bottom vertical frame next to the display. The decal identifies the model number of the unit, the warranty ID number, the serial number, the type of refrigerant and refrigerant charge.

If a concern arises, please refer to the information on this decal, and make a note of the model and serial number before calling for assistance. This information will be needed when you contact an authorized Carrier Transicold Dealer so that they may properly assist you.

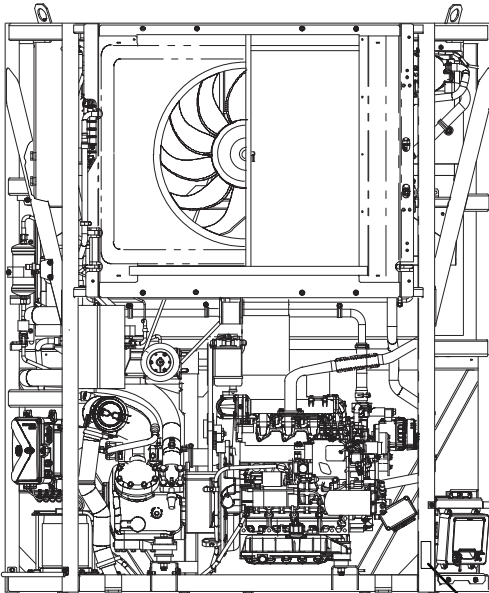

**Nameplate**

**Carrier** Athens Ga.

Model Name: X4 7500  
 SerialNo: #####  
 ModelNo: NDX235####  
 Warranty ID: #####  
 Refrigerant: R404A  
 Standby:  
 Max. Op. Press. LP:100psig/HP#65psig

Manufacturer's Warranty Statement:

Seedealer for warranty coverage details.

DATE IN SERVICE

MONTH			YEAR		
1	2	3	2011		
4	5	6	2012		
7	8	9	2013		
10	11	12	2014		
DAY					
1	2	3	4	5	6
7	8	9	10	11	12
13	14	15	16	17	18
19	20	21	22	23	24
25	26	27	28	29	30
31					

Made in the United States of America

(Sample)



### 3. Safety



**Unit may start automatically at any time even if the switch is in the OFF position. Use proper lockout/tagout procedures before inspection/servicing. All unit inspection/servicing by properly trained personnel only.**

This Carrier Transicold refrigeration unit has been designed with the safety of the operator in mind. During normal operation, all moving parts are fully enclosed to help prevent injury. During all pre-trip inspections, daily inspections, and problem troubleshooting, you may be exposed to moving parts. Please stay clear of all moving parts when the unit is in operation.

#### **NOTE TO TECHNICIANS**

Refer to the Operation and Service manual for a complete list of safety precautions.

#### **3.1 Auto-Start**

This refrigeration unit is equipped with Auto-Start in both Start-Stop and Continuous Operation. The unit may start at any time. A buzzer will sound for five seconds before the unit is started. When performing any check of the refrigeration unit (e.g., visually checking belts, checking the oil), place unit in Inspect mode and disconnect the starter solenoid connector.

#### **3.2 Cooling System**

The engine is equipped with a pressurized cooling system including a pressurized coolant bottle. Under normal operating conditions, the coolant in the engine and radiator is under high pressure and is very hot. Contact with hot coolant can cause severe burns. Do not remove the cap from a hot coolant system. If cap must be removed, cover it with a rag and remove very slowly to release pressure without spray.

#### **3.3 Refrigerant**

The refrigerant contained in the refrigeration system of this unit can cause frostbite, severe burns, or blindness when in direct contact with the skin or eyes. For this reason (and because of legislation regarding the handling of refrigerants) we recommend that you contact your nearest Carrier Transicold authorized repair facility whenever service of the refrigerant system is required.

### **3.4 Battery**

This unit may be equipped with a lead-acid type battery. The battery normally vents small amounts of flammable hydrogen gas. Do not smoke when checking the battery. A battery explosion can cause serious physical harm and/or blindness.

## 4. Display

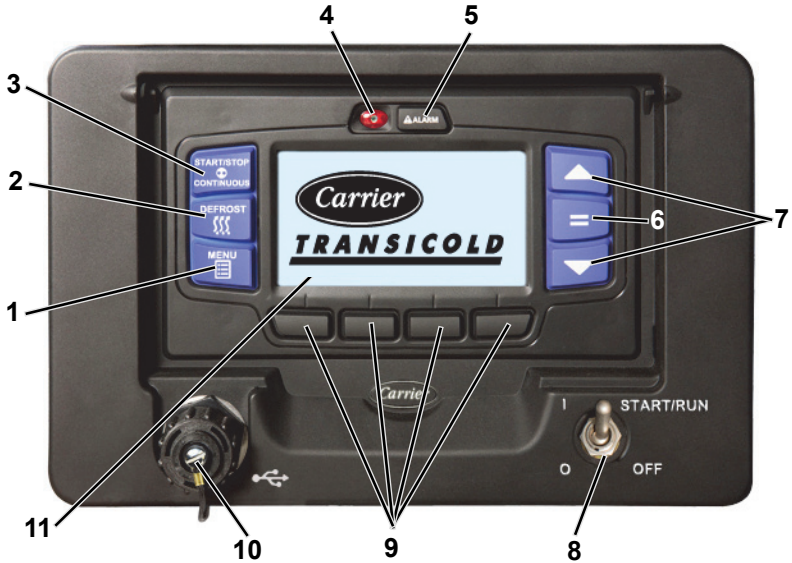

1. MENU Key
2. DEFROST Key
3. START/STOP - CONTINUOUS Key
4. Alarm LED
5. ALARM Key
6. "=" (Select) Key
7. Arrow Keys, ▲ and ▼
8. START/RUN-OFF Switch
9. Soft Keys
10. USB Interface Port (Cover)
11. Display

## 4.1 Display Screens

### Default Screen

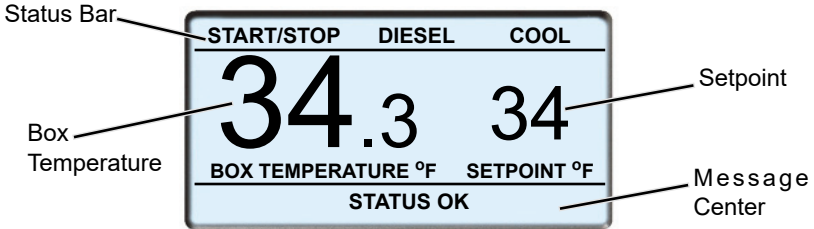

### Typical Menu Screen

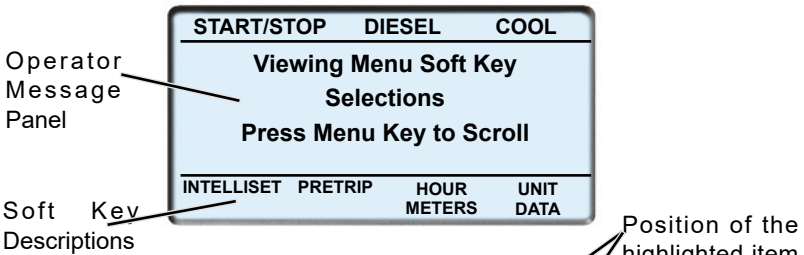

\*Up to five items may be displayed at one time. Press the ▼ key to view additional items, or the ▲ key to scroll back up the list. "END OF LIST" will be displayed after the last item in the list.

## 5. Starting Unit

### **WARNING**

Under no circumstances should ether or any other starting aids be used to start the engine.

### **WARNING**

Unit may start automatically at any time even if the switch is in the OFF position. Use proper lockout/tagout procedures before inspection/servicing. All unit inspection/servicing by properly trained personnel only.



1. Place the START/RUN-OFF switch in the START/RUN position.
2. The system will display the Carrier Transicold logo, display the default screen, present language selection and the hour meter readings (if configured to do so) along with a test flash of the alarm light. The system will then perform a start sequence, energize the buzzer, and then start the unit automatically.

3. If there is an alarm present, the alarm message will be displayed in the MessageCenter and the alarm LED will flash for five seconds. If one or more shutdown alarms are present, the alarm(s) must be cleared before the unit will start.
4. Observe the MessageCenter. If the word “ACTIVE” or “MODIFIED” is displayed at the right, the unit is equipped with IntelliSet™ settings. For more information refer to the **IntelliSet™** Section of this book.

## 6. Inspect Mode

Inspect mode provides an additional layer of safety for operators and technicians. Inspect mode should be used during all pretrip inspections of the unit.

Inspect mode is a user activated feature that forces the unit to shutdown and remain in shutdown regardless of operating state.

After unit inspection, Inspect mode must be manually disabled, at which point the unit will resume standard operation.

Inspect mode is not a substitute for proper Lockout/Tagout procedures, which are always required when servicing the unit.

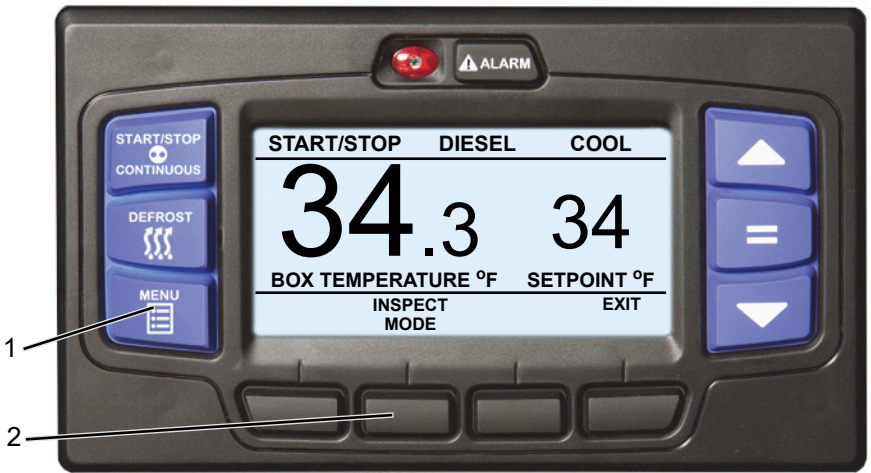

### 6.1 Enter Inspect Mode

1. With the system powered up (START/RUN-OFF switch in the START/RUN position) press the MENU key until INSPECT MODE is displayed.
2. Press the INSPECT MODE soft key, the unit will shut down.

While the unit is in Inspect mode the ALARM light will flash, and the display will indicate that unit operation, including temperature control, has been disabled.

## 6.2 Exit Inspect Mode

1. While the unit is in Inspect mode, the EXIT soft key will be available, all other keys and functions will be locked out.
2. Press the EXIT soft key to disable Inspect mode, the unit will resume standard operation.



2



## 7. IntelliSet™

Products carried or stored in a refrigerated compartment require a multitude of refrigerant unit settings that must be checked and, if required, reset each time a new product is loaded. The APX control system offers the settings necessary to meet these requirements. IntelliSet is a feature that allows pre-selection and naming of the necessary settings for up to 40 different products. The operator may then call up the settings by simply selecting the assigned IntelliSet name.

For example: a load of apples may require continuous operation at 35°F (1.7°C) with a defrost every three hours while a load of cheese may require the same operation with setpoints ranging from 35°F to 42°F (1.7°C to 5.6°C) and a load of ice cream requires start-stop operation at -22°F (-30°C) with defrost at 12 hour intervals. The settings required for each product may be entered into the system and locked so that they cannot be changed, and they can be given an appropriate name. In the case of cheese, the range of setpoints may be locked, leaving the operator the ability to change the setpoint within the locked range.

When a load of apples is going to be picked up, the operator simply selects “APPLES” from the IntelliSet menu. For cheese, “CHEESE” is selected and the setpoint reset as required. For ice cream, “ICE CREAM” is selected. With each selection, the system automatically re-programs the settings to provide the best temperature control, fuel economy, and performance for that particular product.

An IntelliSet may be pre-programmed as “IntelliSleep” which allows Sleep mode to be entered by simply changing to that IntelliSet. Range Protect may be applied to any IntelliSet. Range Protect offers increased fuel savings over normal Start-Stop Operation for commodities that can use less restrictive temperature control.

1. With the system powered up (START/RUN-OFF switch in the START/RUN position) and the default screen displayed, press the “=” key.
2. Press the MENU key until INTELLISET is displayed. Then, press the INTELLISET soft key to display the IntelliSet screen.



- The IntelliSet screen will display with a 15-second timeout and five of the available IntelliSets listed. There may be more than five IntelliSets available. This information is provided, in parenthesis, on the first line. For example, in the illustration below, there are seven IntelliSets available and the second IntelliSet is highlighted. Press the ▲ or ▼ key to scroll through the list of available IntelliSets. The IntelliSet that is currently selected will have the word “ACTIVE” or “MODIFIED” to the right.

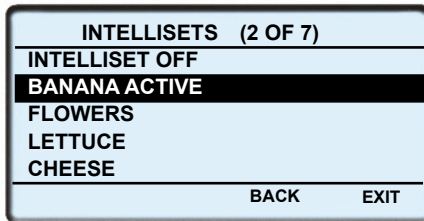

- To change to another IntelliSet, press the ▲ or ▼ key to scroll through the list and highlight the IntelliSet desired. Press the “=” key. The highlighted IntelliSet will become active and an “INTELLISET CHANGED” message will display. Press the EXIT soft key to return to the default display.
- Press the EXIT soft key to return to the default display.

### NOTE

If setpoint change is allowed, refer to [Changing Setpoint](#) for setpoint change instruction.

## 8. Operator Messages

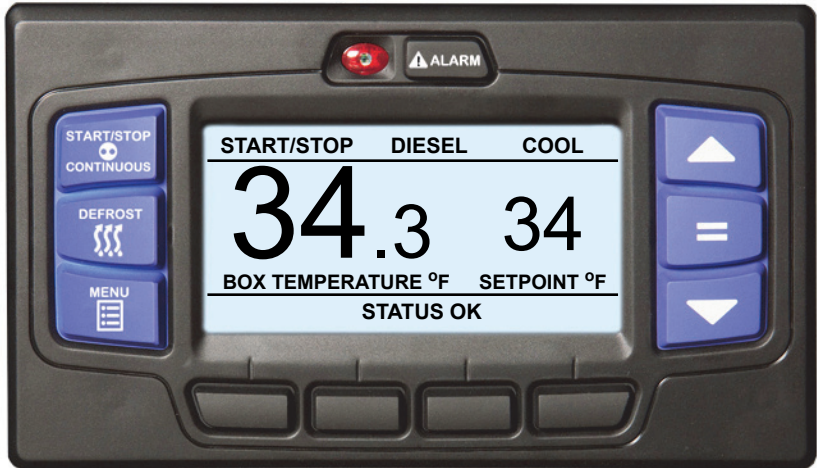

“STATUS OK” - This message or other user-defined message will be displayed in the MessageCenter at most times.

If a problem develops or the operation has been changed, one of the following messages may be displayed:

**CHECK AT NEXT SERVICE INTERVAL:** Displayed when there is an active non-shutdown alarm present (the alarm condition is present but is not serious enough to shut down the unit). These alarms may be viewed by pressing the Alarm key. The message will clear itself when the condition is corrected.

**DOOR OPEN:** Displayed if an optional door switch is installed and configured to notify you when the door is opened or not closed tightly.

**LOSS OF COMMUNICATIONS:** Displayed when there is a problem between one or more modules and the display module.

**CHECK FUEL LEVEL:** Displayed if an optional fuel level sensor is installed in the tank, the level is low and fuel needs to be added.

**DOOR OPEN - LOW SPEED or REMOTE SWITCH OPEN - LOW-SPEED:** Displayed if an optional door or remote switch is installed and configured to operate the engine in low speed when the refrigerated compartment door is opened or remote switch is activated.

**SLEEP MODE, OFF / ON TO WAKE:** Displayed when the unit is in Sleep Mode, and the engine has cycled off.

**SLEEP WARNING NO TEMP CONTROL:** Displayed when the unit is running while in Sleep Mode.

**TECHNICIAN RESET REQUIRED:** Displayed if certain alarms or a combination of alarms have been activated a defined number of times within a set amount of time. The unit must be brought to a Carrier Transicold Dealer for service.

**BATTERY VOLTAGE TOO LOW:** Displayed when the unit battery voltage is too low to allow the unit to start and run.

**UNIT SHUTDOWN - DOOR OPEN or REMOTE SWITCH:** Displayed if an optional door or remote switch is installed and configured to shut the unit down when the compartment door is opened or remote switch is activated.

**UNIT SHUTDOWN - SEE ALARM LIST:** Displayed when there is a safety shutdown. Pressing the Alarm key will bring any active alarms into the MessageCenter.

**WARNING: NO TEMP CONTROL:** Displayed when:

- System is not performing up to capacity and there is an active temperature control alarm.

**OR**

- Both refrigerated compartment temperature sensors (return air and supply air) have failed, the compartment has a frozen setpoint and the compartment is only operating in cool mode.

## 9. Pretrip

Pretrip is a set of tests run by the system to check unit operation. It is recommended that a Pretrip is run prior to loading the refrigerated compartment. It will indicate a failure if one is detected.



1. With the system powered up (START/RUN-OFF switch in the START/RUN position) press the MENU key until PRETRIP is displayed.
2. Press the PRETRIP soft key to display the PRETRIP MENU screen, which will display with a 15-second timeout.
3. Use the ▲ or ▼ key to select START PRETRIP, then press the “=” key.

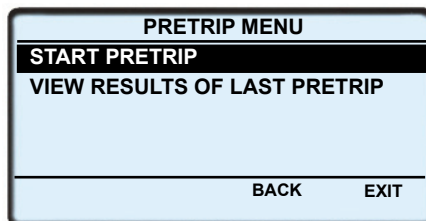

- If START PRETRIP is selected, Pretrip will begin and the PRETRIP STATUS screen will be displayed. Immediately following Pretrip OR if “View Results of Last Pretrip” is selected the PRETRIP SUMMARY SCREEN will be displayed.

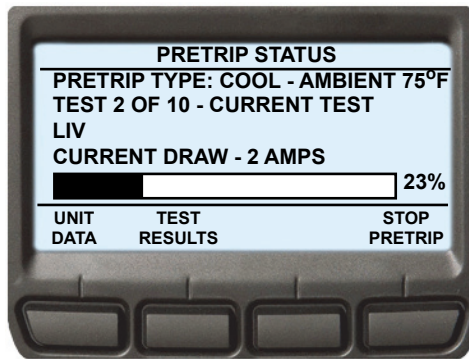

### NOTE

At any time during Pretrip, the UNIT DATA soft key may be pressed to allow the user to view the unit data screen, refer to [Unit Data](#). To return to Pretrip, press the BACK soft key.

### NOTE

During Pretrip the ALARM light will illuminate to indicate there is no temperature control.

- During Pretrip Test 1, verify that both lights on the light bar are illuminated, the buzzer is energized and the AutoFresh air port opens and closes (if equipped).
- The remainder of the Pretrip tests will run automatically and take 7 to 15 minutes. The percent of Pretrip that has been completed is displayed in the status bar under the test description information.
- “PRETRIP PASS”, “PRETRIP FAIL IN TEST ##” or “PRETRIP FAILED AND COMPLETE” will be displayed at the end of the testing. The “PASS” message will display until a key is pressed. The Pretrip test “FAIL” results message will display until the alarms are cleared.

### TIP

To end Pretrip at any time, press STOP PRETRIP.

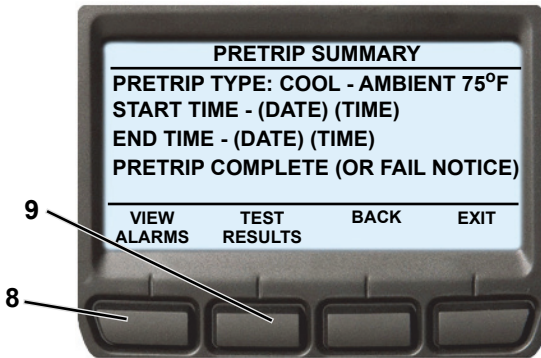

8. Press the VIEW ALARMS soft key to move to the Alarm Screen (refer to [Alarm List](#)) and review any alarms activated during the test.
9. Press the TEST RESULTS soft key to view details of the test results. Press the ▼ or ▲ key to scroll through the results.

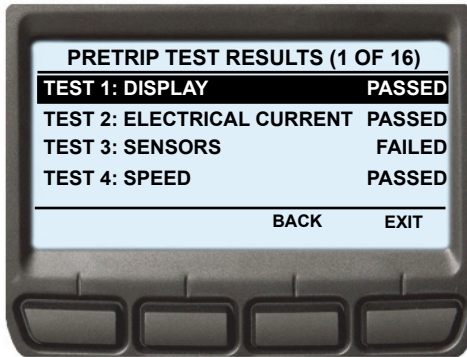

## 10. Changing Setpoint

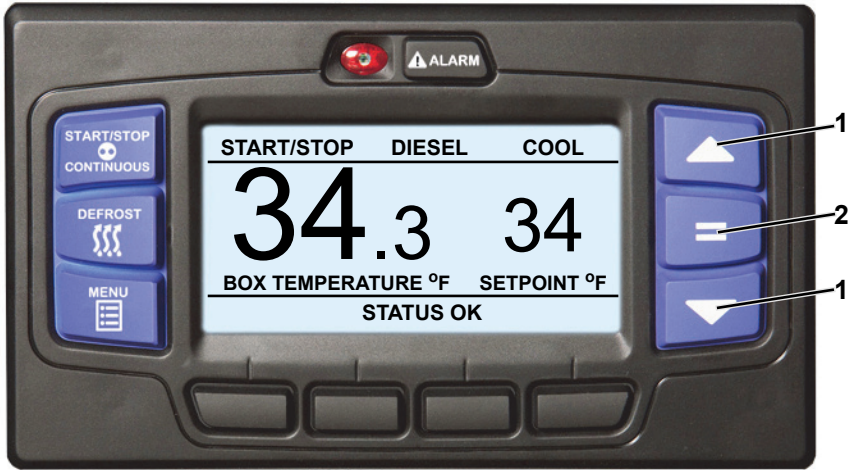

1. With the system powered up (START/RUN-OFF switch in the START/RUN position) and the default screen displayed (press the BACK or EXIT soft key if required), press the ▲ or ▼ key to bring the displayed setpoint to the desired value.

### TIP

The setpoint will change one degree (or 0.1 degree if configured to do so) with each press and release of an arrow key or the setpoint will scroll if the key is pressed and held.

2. Press the “=” key to save the new setpoint. The MessageCenter will display “SETPOINT CHANGED” for 10 seconds.
3. If the “=” key is not pressed the setpoint screen will flash, the MessageCenter will display “SETPOINT NOT CHANGED” and then return to original setpoint. Alarm 04004 “NO SETPOINT CHANGE” will be activated.

### NOTE

The setpoint range is from -22°F to +90°F (-30°C to +32°C). This range may not be fully accessible, depending on the settings for this system. If the message “MAX SETPOINT HAS BEEN REACHED” or “MIN SETPOINT HAS BEEN REACHED” is displayed, the setpoint range has been locked and can not be changed outside the range.



## 11. Start-Stop or Continuous Operation

Start-Stop is provided to reduce fuel consumption. This feature allows full automatic control of the unit starting and stopping by monitoring compartment temperature, battery charge condition and engine coolant temperature. The main function of Start-Stop Operation is to turn off the refrigeration system near setpoint to provide an efficient temperature control system and to initiate a restart sequence after certain conditions are met.

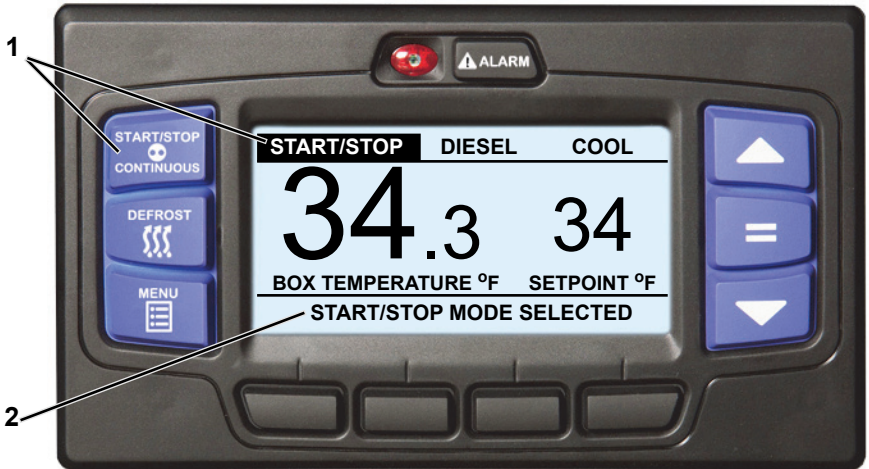

1. With the system powered up (START/RUN-OFF switch in the START/ RUN position) press the START-STOP/CONTINUOUS key until the desired operation (Start/Stop or Continuous) is highlighted.
2. “START/STOP MODE SELECTED” or “CONTINUOUS RUN MODE SELECTED” will be displayed in the MessageCenter for 10 seconds.
3. The operation indication in the status bar will no longer be highlighted. The unit is now running in the displayed mode.

### NOTE

If “CONTINUOUS LOCKED” or “START/STOP LOCKED” is displayed, the system is currently locked into the displayed mode of operation and cannot be changed using the “START/STOP - CONTINUOUS” key.

**Whenever the unit starts in Start-Stop, it will run until:**

- The selected minimum run time has expired.
- The compartment temperature is at setpoint.
- The battery is fully charged (as indicated in the MessageCenter by “OK” after the voltage value) AND the charging amps are less than the Configuration setting.
- The engine coolant temperature rises above 122°F (50°C).

**A restart will be initiated when one of the following conditions occurs:**

- During the Minimum Off Time compartment temperature has moved away from setpoint by 3.6° to 18°F (2° to 10°C) depending on the Functional Parameter settings.
- The Minimum Off Time has expired and the compartment temperature has moved away from setpoint by more than the Restart Functional Parameter setting, 0.5 to 18 °F (2° to 10°C).
- Engine coolant temperature drops below the configured setting, 10 to 32°F (-12.2° to 0°C).
- The battery voltage falls below the configured setting (12.0 to 12.8 V).
- Maximum Off Time has expired. The Maximum Off Time setting ensures that the entire load stays within safe temperature range. The unit will start after a pre-selected maximum off time-regardless of any change in compartment temperature.

If the engine fails to start after three start attempts, alarm 31 - “FAILED TO START-AUTO MODE” will be activated. While running, if the unit shuts down on a safety, or fails to run for the minimum run time, three consecutive times, alarm 30 - “FAILED TO RUN MINIMUM TIME” will be activated. The shutdown counter is cleared when the engine has run for 15 minutes, or when the unit cycles off normally.

In Continuous Operation the unit will not shut down, except in response to a shut down alarm. Continuous Operation provides constant air flow and temperature control for the product.

Refer to **Recommended Transport Temperatures** for suggested Start-Stop and Continuous Operation settings.

## 12. Data Recorder / Trip Start

The Data Recorder records data while the START/RUN - OFF switch is in the START/RUN position.



1. With the system powered up (START/RUN-OFF switch in the START/RUN position) press the MENU key until DATA RECORDER is displayed.
2. Press the DATA RECORDER soft key to display the sub menu.

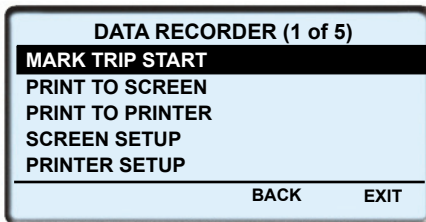

Choices vary based on software revision and model type.

3. The Data Recorder screen will display with a 15-second timeout. Press the ▲ or ▼ key to scroll through the available sub menus. With the desired sub-menu highlighted, press the “=” key to enter the menu.

### 12.1 Mark Trip Start

Trip Start places the present time and date as a stamp in the data recorder memory to allow easy review of the data from the last trip, and to allow downloading data from a specific trip. A trip begins at a Trip Start and ends at the next Trip Start.

To Enter a Trip Start, with MARK TRIP START highlighted, press the “=” key. If trip start is acknowledged by the data recorder, “TRIP START ENTERED” will be displayed for 15 seconds and then the display will return to the Data Recorder screen. In the unlikely situation that the data recorder is not functioning properly “CANNOT ENTER TRIP START” will flash and then the display will revert back to the Data Recorder menu.

#### **NOTE**

If configured to do so, the system will prompt for entry of a customer specific data protect PIN code before any data recorder print functions can be used. If this code is not entered, all print functions are locked out.

## 13. Manual Defrost



1. With the system powered up (START/RUN-OFF switch in the START/ RUN position) press the MANUAL DEFROST key.
2. If the conditions for defrost are met, the status bar and the Box Temperature display will change to the word “DEFROST”. The MessageCenter will display “DEFROST CYCLE STARTED” for 10 seconds. At the completion of any defrost cycle, the MessageCenter will return to the default display.
3. If the conditions for defrost are not met, the MessageCenter will display “CANNOT START DEFROST CYCLE” for five seconds. This message will be activated when:
  - The box temperature is too warm. Defrost may be entered when the defrost termination temperature sensor (DTT) is below 40°F (4°C) or the supply air temperature sensor (SAT) is below 45°F (7.2°C) **OR**
  - The engine has not run at least 15 seconds after starting **OR**
  - The system is in PC mode **OR**
  - The unit is in Pretrip **OR**
  - There is an active shutdown alarm.

Defrost may also be initiated automatically at preset intervals by the system defrost timer or by the defrost air switch.

The defrost mode terminates when the defrost termination temperature sensor (DTT) and the supply air temperature sensor (SAT) both rise higher than 55°F (12.8°C). Should the defrost cycle not end after a maximum of 45 minutes, the defrost cycle is terminated automatically. "DEFROST NOT COMPLETE" will be displayed in the MessageCenter.

If defrost terminates on the 45-minute termination timer, the system will wait 1.5 hours of compressor running time before attempting an automatic defrost cycle. Pressing the manual defrost key will override this mode and start a defrost cycle.

## 14. Language Selection



### NOTE

Language selection may not be available on early software revisions.

1. With the system powered up (START/RUN-OFF switch in the START/RUN position) press the MENU key until LANGUAGE is displayed.
2. Press the LANGUAGE soft key to display the LANGUAGE screen.

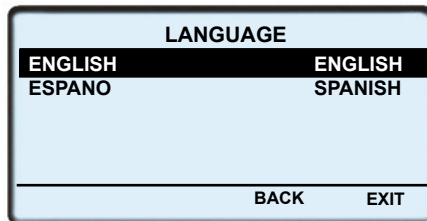

3. The LANGUAGE screen will display with a 10-second timeout. Press the ▲ or ▼ key to scroll through the available selections.
4. With the desired language highlighted, press the “=” key. The highlighted language will become active and “LANGUAGE CHANGED” will be displayed.

## 15. Unit Data



1. With the system powered up (START/RUN-OFF switch in the START/ RUN position), press the MENU key until UNIT DATA is displayed.
2. Press the UNIT DATA soft key to display the unit data screen.

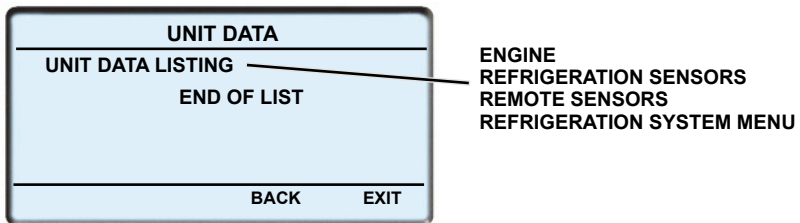

3. The Unit Data screen will display with a 15-second timeout. Press the ▲ or ▼ key to scroll through the available unit data sub menus. With the desired sub-menu highlighted, press the “=” key to view the data.



4. The selected sub-menu data will be displayed. For example, the REFRIGERATION SENSORS display may include:

REFRIGERATION SENSORS (1 OF 5)	
AMBIENT AIR TEMP:	75.0°F
RETURN AIR TEMP:	38.0°F
SUPPLY AIR TEMP:	37.0°F
DELTA T:	-1.0°F
DEFROST TERM TEMP:	39.0°F
LOCK SCREEN	BACK EXIT

5. Press the ▲ or ▼ key to scroll through the sub-menu data list.
6. To lock the present display view, press the LOCK SCREEN soft key. The screen will highlight (white lettering on a black background) to indicate it is locked and the soft key will change to UNLOCK SCREEN.
7. Press the UNLOCK SCREEN soft key to unlock the screen or press the ▲ or ▼ key to unlock the screen and scroll through the sub-menu data selections. Press the BACK key to return to the sub-menu selection screen or the EXIT soft key to return to the default screen. Refer to the following table for additional information on Unit Data.

<b>Engine</b>	<b>Remote Sensors (Optional)</b>
Fuel level	Remote Sensor 1
Battery	Remote Sensor 2
Amp Draw	Remote Sensor 3
Engine Coolant Temperature	
Unit AC Current #1	<b>Refrigeration System</b>
	Compressor Suction Pressure
<b>Refrigeration Sensors</b>	
Ambient Air Temp	
Return Air Temp	
Supply Air Temp	
Delta T	

DATA	DEFINITION
FUEL LEVEL	% of fuel in tank. (This is only displayed when an optional fuel level sensor is installed and configured ON)
BATTERY	Battery voltage
AMP DRAW	Battery charging or discharging amps
ENGINE COOLANT TEMP	Engine coolant temperature
AMBIENT AIR TEMP	Ambient (air entering condenser) air temperature
RETURN AIR TEMP	Return (air entering evaporator) air temperature
SUPPLY AIR TEMP	Supply (air leaving evaporator) temperature
DELTA-T	Supply air temperature minus return air temperature (a negative value indicates cooling and a positive value indicates heating)
DEFROST TERM TEMP	Defrost termination temperature
REMOTE SENSOR (1 OR 2)	This is the temperature at remote Temperature Sensor 1 or 2. (These sensors are optional, and may not be applicable to this unit.)
SUCTION PRESSURE	Compressor suction pressure

## 16. Alarm List



1. With the system powered up (START/RUN-OFF switch in the START/ RUN position) press the ALARM key.
2. If there are active alarms, the alarm number will be displayed preceded by the letter “A” (active alarm). The system may also be configured to display an alarm description, following the alarm number. The last alarm that occurred will be the first alarm displayed and so on.
3. Next to the ACTIVE ALARMS screen name in the status bar, information on the total number of alarms and the position in the list of the highlighted alarm is provided. (In the preceding illustration there are three alarms and the first alarm is highlighted.)
4. Press the ▲ or ▼ key to scroll through the list of alarms.
5. To clear the alarms, press the CLEAR ALARMS soft key. The display will provide an “ACTIVE ALARMS CLEARED” message and then return to the default display after 10 seconds.
6. If there are no active alarms, the display will provide a “NO ACTIVE ALARMS” message and then return to the default display after five seconds.

## 17. View Hour Meters



1. With the system powered up (START/RUN-OFF switch in the START/ RUN position), press the MENU key until HOUR METERS is displayed.
2. Press the HOUR METERS soft key to display the hour meter screen.

STANDARD HOUR METERS (3 OF 4)	
ENGINE HOURS	1050 HOURS
<b>SWITCH ON HOURS</b>	<b>1400 HOURS</b>
TOTAL RUN HOURS	1050 HOURS
END OF LIST	
LOCK SCREEN	BACK EXIT

3. The hour meter screen will display with a 15-second timeout. Press the EXIT soft key to return to the default screen.

## 18. Stopping Unit



To stop the unit, place the START/RUN-OFF switch in the OFF position. The refrigeration system and engine will shut down immediately while the control system completes a shut down sequence, and then the display will go blank.

### NOTE

The system will close the compressor suction modulation valve (CSMV) and evaporator expansion valve (EVXV) before turning off.

Due to internal processing, turning the START/RUN - OFF switch OFF then back to the START/RUN position will result in a 4 to 50 second delay between the display going off and coming back on again.



### WARNING

Unit may start automatically at any time even if the switch is in the OFF position. Use proper lockout/tagout procedures before inspection/servicing. All unit inspection/servicing by properly trained personnel only.

## 19. Emergency Bypass Mode

In the event of an alarm caused by a failure of the display module, the refrigeration unit will go into shutdown. To temporarily bypass this shutdown state, Emergency Bypass mode can be activated.

Once Emergency Bypass mode has been activated, the refrigeration unit will operate normally for 24 hours. A countdown timer will be shown on the display. This 24-hour window of operation will keep the load safe, and provide enough time to contact the nearest Carrier Transicold Service Center for repair of the unit.

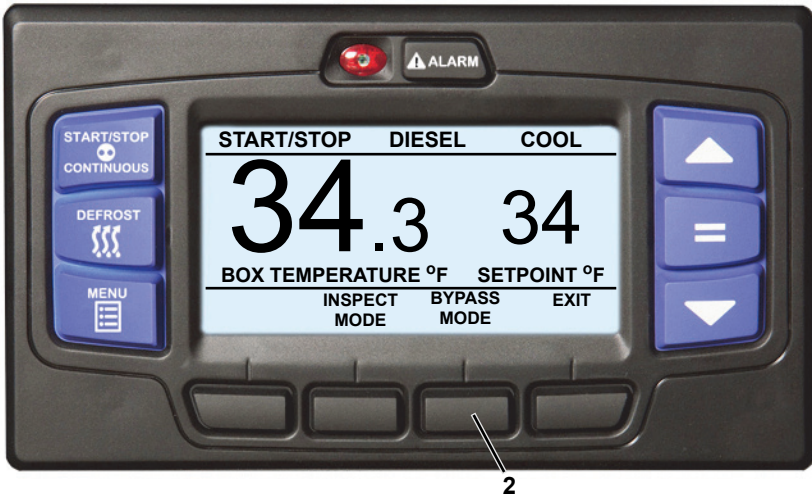

### 19.1 Enter Emergency Bypass Mode

1. When the refrigeration unit is in a shutdown state due to the display module alarm, press the MENU key until BYPASS MODE is displayed.
2. Press the BYPASS MODE soft key, the unit will resume operation until Emergency Bypass mode is disabled, or after 24 hours of unit operation in Emergency Bypass mode.

### 19.2 Exit Emergency Bypass Mode

1. Press the MENU key until the EXIT BYPASS soft key is displayed.
2. Press the EXIT BYPASS soft key, the refrigeration unit will shut down. Once Emergency Bypass mode is turned off, it cannot be restarted and the unit will remain in shutdown until it is repaired.

After repairs have been made and the display module alarm has been cleared, the unit will operate normally and Emergency Bypass mode will no longer be available.

## 20. Pretrip Inspection

The Pretrip Inspection should be performed before picking up any load. This inspection is essential to ensure reliable operation of this unit. These checks take only a few minutes.



### WARNING

**Unit may start automatically at any time even if the switch is in the OFF position. Use proper lockout/tagout procedures before inspection/servicing. All unit inspection/servicing by properly trained personnel only.**

#### BEFORE STARTING ENGINE

Place unit in Inspect mode and disconnect starter solenoid connector

Drain water from bottom of fuel tank

Drain water from water separator on fuel filter (if applicable)

Check radiator coolant level

Check air cleaner indicator

Check engine oil level

Visually check condition of belts

Check door latches and hinges

Check battery cables for rubbing or chafing

Check battery terminals for cleanliness

Check channels or "T" bar floor as well as return air bulkhead for cleanliness and obstruction. Channels and return air bulkhead must be free of debris for proper air circulation.

Check air chute

Exit Inspect mode and reconnect starter solenoid connector

Start unit and place in continuous operation

#### IMMEDIATELY AFTER STARTING ENGINE

Visually check fuel lines and filters for leaks

Visually check oil lines and filters for leaks

Visually check coolant hoses for leaks

Visually check exhaust system for leaks

Verify correct air flow of condenser fan\*

\* Place a small rag in front of the condenser coil, the rag should hold. If the rag blows away it means that the fan is rotating in reverse.



**AFTER 15 MINUTES OF OPERATION**

Initiate defrost and allow to terminate automatically

Check defrost drain line for blockage and proper water flow

**PRETRIP**

Initiate Pretrip

List any Pretrip alarms

**FINAL**

Enter trip start in micro

**COMMENTS / NOTES**

--

## **21. Product Loading**

### **21.1 Before Loading**

- Pre-cool the compartment. This will remove much of the heat from the inside of the compartment (including the walls and insulation) and give the product better protection when it is loaded.
- If possible, Place the unit in a defrost cycle immediately before loading. This will remove moisture accumulated on the evaporator coil.

### **21.2 During Loading**

- Stop the unit (place the START/RUN-OFF switch in the OFF position).
- Check product temperature during loading.
- Ensure that the air returns and supply openings remain unobstructed.
- Leave approximately 4 to 5 inches (100 to 125 mm) between the load and compartment front wall for air return to the unit.
- Leave at least 10 to 12 inches (250 to 300 mm) between the top of the load and the ceiling to ensure that there is nothing to prevent airflow.
- Load product on pallets to provide free air return to unit and improve product protection.

Proper air circulation in the compartment, air that can move around and through the load, is a critical element in maintaining product quality during transport. If air cannot circulate completely around the load, hot spots or top-freeze can occur.

The use of pallets is highly recommended. Pallets, when loaded so air can flow freely through the pallets to return to the evaporator, help protect the product from heat passing through the floor of the trailer. When using pallets, it is important to refrain from stacking extra boxes on the floor at the rear of the compartment as this will cut off the airflow.

Product stacking is another important factor in protecting the product. Products that generate heat - fruits and vegetables, for example - should be stacked so the air can flow through the product to remove the heat. This is called "air stacking" the product. Products that do not create heat - meats and frozen products - should be stacked tightly in the center of the trailer. All products should be kept away from the side-walls of the body, to allow air flow between the body and the load preventing heat filtering through the walls from affecting the product.

It is important to check the temperature of the product being loaded to ensure that it is at the correct temperature for transport. The unit is designed to maintain the temperature of the product at the temperature at which it was loaded. It was not designed to cool warm product.

## 22. Recommended Transport Temperatures

Some general recommendations on product transport temperatures and operating modes for the unit are listed in the following chart. These are included for reference only and should not be considered preemptive of the setpoint required by the shipper or receiver.

More detailed information can be obtained from your Carrier Transicold dealer.

Product	Setpoint Range		Operation <sup>1</sup>
	°F	°C	
Bananas	56 to 58	13 to 14	Continuous
Fresh fruits and vegetables	33 to 38	0.5 to 3	Continuous
Fresh meats and seafood	28 to 32	-2 to 0	Start/Stop or Continuous
Dairy products	33 to 38	0.5 to 3	Start/Stop or Continuous
Ice	15 to 20	-10 to -7	Start/Stop <sup>2</sup>
Frozen fruits and vegetables	-10 to 0	-23 to -18	Start/Stop <sup>2</sup>
Frozen meats and seafood	-10 to 0	-23 to -18	Start/Stop <sup>2</sup>
Ice cream	-20 to -15	-29 to -26	Start/Stop <sup>2</sup>

<sup>1</sup>During delivery cycles that include frequent stops and door openings, the unit should always be operated in Continuous Operation to help ensure product quality. If it is possible, the unit should be turned off during the time the trailer doors are open to help conserve the product temperature.

<sup>2</sup>Variations may be necessary for very high or very low ambient temperatures.

## 23. General Troubleshooting



### WARNING

**Unit may start automatically at any time even if the switch is in the OFF position. Use proper lockout/tagout procedures before inspection/servicing. All unit inspection/servicing by properly trained personnel only.**

Everything possible has been done to ensure that this unit is the most reliable, trouble-free equipment available today. If, however you are having an issue, the following section may be of assistance.

If you do not find the trouble that you have experienced listed, please call your Carrier Transicold dealer for assistance.

<b>General Troubleshooting</b>	
<b>Unit won't crank</b>	Check alarm list Visually check battery condition Visually check battery connections Check all fuses
<b>Unit won't start</b>	Check alarm list Check fuel level Check all fuses
<b>Unit won't run</b>	Check alarm list Check fuel level Check engine oil level Check all fuses
<b>Unit stops operating</b>	Check alarm list Visually check belts Check engine oil level Visually check coolant level Check fuel level Check all fuses

<b>Unit not cooling/heating properly</b>	Check alarm list Initiate Manual Defrost of unit, refer to <b>Manual Defrost</b> . Check for proper air circulation in the refrigerated compartment. Check condenser for airflow restriction Check refrigerated compartment for damage or air leaks.
--	--

## 24. Fuses

Fuses are located in the Control Box (engine side of unit) and either the Power Control Module (PCM) or the Power Module (PM) located above the battery. Fuses in the control box are 600 VAC and fuses in the PM/PCM are 12 VDC.

### Power Module (PM)

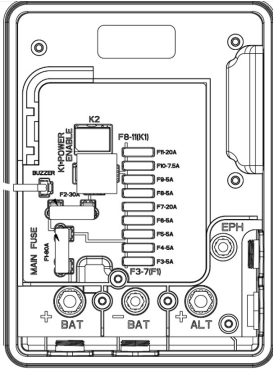

Fuse	Purpose	Amps
F1	Main	80
F2	Power Enable Relay (PER)	30
F3	Battery Guard (Option)	5
F4	ENCU / Remote Panel (Option)	7.5
F5	Micro / Stepper Module (MSM)	5
F6	Logic	5
F7	Fuel Heat / AFAX (Option)	20
F8	Not Used	5
F9	Not Used	5
F10	Engine Control Unit (ENCU)	7.5
F11	System Loads (SV, UL, Clutch, SS, FP)	20

### Power Control Module (PCM)

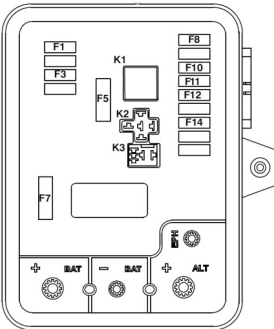

Fuse	Purpose	Amps
F1	Buzzer / Logic	5
F2	Not Used	5
F3	Engine Control Unit (ENCU)	5
F4	eSolutions Constant (Option)	5
F5	Power Enable Relay (PER)	30
F6	AFAX (Option) (inline fuse)	10
F7	Main	80
F8	EES / Fuel Level Sensor (Option)	10
F9	Not Used	5
F10	Main Micro (MM)	20
F11	Light Bar (LB)	5
F12	eSolutions Switch (Option)	5
F13	Not Used	5
F14	Fuel Heat	15
F15	Not Used	10
F16	Not Used	10

## 25. Unit Maintenance

### 25.1 Maintenance Schedule

For the most reliable operation and for maximum life, this unit requires regular maintenance. This includes oil and filter changes, fuel filter and air cleaner replacement and coolant replacement. Maintenance should be performed by properly trained personnel on the following schedule:



**Unit may start automatically at any time even if the switch is in the OFF position. Use proper lockout/tagout procedures before inspection/servicing. All unit inspection/ servicing by properly trained personnel only.**

SYSTEM	OPERATION
<b>a. Pretrip Inspections</b>	
	<ol style="list-style-type: none"><li>1. Pretrip Inspection - See <b>Pretrip Inspection</b></li><li>2. Run Microprocessor Pretrip - Before loading, see <b>Pretrip</b></li><li>3. Check Engine Hours</li></ol>
<b>b. Every Service Interval or Yearly</b>	
<b>Engine</b>	<ol style="list-style-type: none"><li>1. Check engine oil and filter change interval</li><li>2. Check low oil pressure switch</li><li>3. Clean crankcase breather</li><li>4. Check fuel injectors every 1,500 hours<sup>1</sup></li><li>5. Check injection pump every 3,000 hours<sup>1</sup></li><li>6. Check and adjust engine valves every 4,000 hours</li></ol>
<b>Fuel System</b>	<ol style="list-style-type: none"><li>1. Clean mechanical and electric (if equipped) fuel pump screens</li><li>2. Change fuel filter</li><li>3. Check fuel heater (if equipped)</li></ol>
<b>Cooling System</b>	<ol style="list-style-type: none"><li>1. Check coolant change interval. If replacement is not required, check antifreeze concentration using a refractometer (Carrier Transicold P/N 07-00435-00)</li><li>2. Clean condenser/radiator surfaces</li><li>3. Check water pump</li><li>4. Check water temperature sensor</li></ol>
<b>Exhaust System</b>	<ol style="list-style-type: none"><li>1. Check mounting hardware</li><li>2. Check muffler and exhaust pipes</li></ol>

<b>SYSTEM</b>	<b>OPERATION</b>
<b>Air Intake System</b>	<ol style="list-style-type: none"> <li>1. Change air cleaner element</li> <li>2. Check and reset air cleaner indicator</li> </ol>
<b>Starting Circuit</b>	<ol style="list-style-type: none"> <li>1. Clean battery connections and cable ends</li> <li>2. Check battery hold down clamps</li> <li>3. Check battery condition</li> <li>4. Check starter operation</li> </ol>
<b>b. Every Service Interval or Yearly (Continued)</b>	
<b>Charging Circuit</b>	<ol style="list-style-type: none"> <li>1. Check alternator brushes, replace if needed</li> <li>2. Check alternator output</li> </ol>
<b>Unit</b>	<ol style="list-style-type: none"> <li>1. Check unit mounting bolts</li> <li>2. Check engine and compressor mounting bolts</li> <li>3. Check door latches and hinges</li> <li>4. Check all belt tensions, adjust as necessary</li> <li>5. Check gearbox and fanshaft for oil leaks</li> <li>6. Check fanshaft, idler and gearbox bearings</li> <li>7. Check clutch air gap, adjust as required</li> </ol>
<b>Refrigeration System</b>	<ol style="list-style-type: none"> <li>1. Check compressor drive coupling</li> <li>2. Check defrost air switch and calibrate as necessary</li> <li>3. Remove bulkhead (if equipped). Check and clean the evaporator coil and all defrost drain hoses</li> <li>4. Install manifold gauge set and check refrigerant pressure</li> <li>5. Run APX Control System Pretrip</li> <li>6. Check manual defrost operation</li> </ol>
<b>Electrical System</b>	<ol style="list-style-type: none"> <li>1. Check unit switches and electrical connections</li> <li>2. Check condition of all modules</li> </ol>
<b>c. 5 Year or 12,000 Hour Maintenance</b>	
<b>Coolant System</b>	<ol style="list-style-type: none"> <li>1. Drain and flush cooling system.</li> <li>2. Refill with Extended Life Coolant</li> </ol>
<b>d. Oil Change Intervals</b>	
<b>Oil Type</b>	<b>Oil Change / ESI Filter Change</b>
Petroleum	3000 hours or 2 years (Maximum oil drain interval is 2 years)
Mobil Delvac 1 <sup>2</sup>	4000 hours or 2 years (Maximum oil drain interval is 2 years)
1 = Based on EPA 40 CFR Part 89	
2 = Mobil Delvac 1 is the only approved synthetic oil	

These maintenance schedules are based on the use of approved oils and regular pretrip inspections of the unit. Failure to follow the recommended maintenance schedule may affect the life and reliability of the refrigeration unit.



## 25.2 Engine Oil

The petroleum oils recommended for use in this refrigeration unit must comply with the American Petroleum Institute (API) Class CG or better rating. The only recommended synthetic oil is Mobil Delvac 1. The use of any oil that does not meet this rating may affect the warranty on the engine. The use of oil of the proper weight (viscosity) is also essential. The following chart indicates the SAE weight rating of the oil to be used in various climates:

SAE Weights		
Outdoor Temperature		SAE
Fahrenheit	Centigrade	
Below 32°	Below 0°	10W 30 or Mobil Delvac 1 (5W 40)
Above 32°	Above 0°	10W 30 or Mobil Delvac 1 (5W 40) or 15W 40

## 25.3 Checking Engine Oil

Run the unit to bring the engine up to operating temperature, shut the unit off, and remove the cap/dipstick. Wipe the dipstick clean and insert it into the oil fill tube without threading it all the way back into the tube. Remove the dipstick again and check oil level. DO NOT add oil if the level is in the “safe” range. If needed, add oil as indicated by markings on dipstick until level is in the “safe” range.

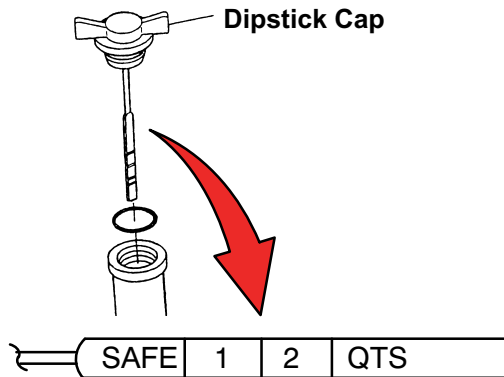

## 25.4 Priming Fuel System

The mechanical fuel lift pump is mounted on the engine next to the injection pump. This pump has a manual plunger for priming the fuel system when the fuel tank has been run dry.



### WARNING

**Keep clear of rotating belt and pulleys.**

**To prime the fuel system, use the following steps:**

1. Turn the bleed valve (red) counter-clockwise until fully opened.
2. Turn the top of the manual fuel pump plunger counter-clockwise to unlock it. S-L-O-W-L-Y (up/down once per second) pump the manual plunger until positive pressure (resistance) is felt. This may take up to 200 strokes. Positive pressure indicates fuel flow.
3. Continue to pump S-L-O-W-L-Y (up/down once per second) approximately 100 more strokes to fill the filter and bleed the air out of the lines.
4. Start engine. It may be necessary to continue to pump until the engine starts.

### NOTE

Running the engine for an extended period of time with the manual plunger up can cause a priming pump failure.

5. Depress and turn the top of the manual plunger clockwise to lock in place.
6. When the engine is running smoothly, turn bleed valve clockwise until fully closed.

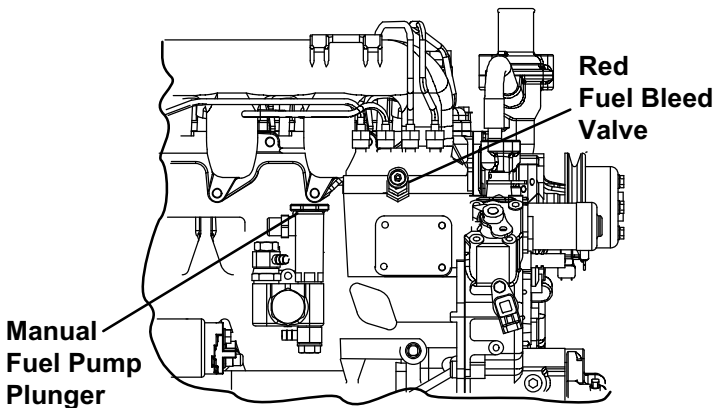

## **26. Warranty**

Carrier Transicold offers warranty coverage to the initial and subsequent owners during the warranty coverage period. The warranty coverage terms are available on request through the Carrier Transicold dealer network. For the X4 7300 or X4 7500, please request 62-11669 for the manufacturer's warranty document. For the X4 7300R or X4 7500R, please request 62-11670 for the manufacturer's warranty document

## 27. Emergency Road Service

At Carrier Transicold we're working hard to give you complete service when and where you need it. That means a worldwide network of dealers that offer 24-hour emergency service. These service centers are manned by factory trained service personnel and backed by extensive parts inventories that will assure you of prompt repair.

Should you experience a problem with your unit during transit, follow your company's emergency procedure or contact the nearest Carrier Transicold service center. Consult the Shortstop Service Centers directory or visit [www.trucktrailer.carrier.com](http://www.trucktrailer.carrier.com) and click on "Dealer Locator" to locate the service center nearest you. The Shortstop directory may be obtained from your Carrier Transicold dealer.

You can also download the Carrier Transicold North America Truck/Trailer Dealer Locator App to your smart phone. The Dealer Locator App provides:

- Location information for every Carrier Transicold dealer in North America
- The nearest dealer from your present location
- Dealer look-up capability
- Dealer services (Trailer, Truck, APU, Mobile Support, etc.)
- Addresses
- Maps to easily find dealers
- Directions and navigation to the dealerships
- Phone number and 24-hour emergency hotlines, where available
- Auto dialing
- Hours of operation
- Link to dealer website
- Ability to add dealers to Contacts

To download the Carrier Transicold North America Truck/Trailer Dealer Locator App, scan this QR code, or go directly to your App store.



If you are unable to reach a service center, call our 24-hour Action Line: (800) 448-1661

We will do everything we can to get your problem taken care of by an authorized CTD dealer and get you back on the road.



 **WARNING:** Breathing diesel engine exhaust exposes you to chemicals known to the State of California to cause cancer and birth defects or other reproductive harm.

- Always start and operate engine in a well-ventilated area.
- If in an enclosed area, vent the exhaust to the outside.
- Do not modify or tamper with the exhaust system.
- Do not idle the engine except as necessary.

For more information, go to [www.P65warnings.ca.gov/diesel](http://www.P65warnings.ca.gov/diesel)



North America  
Carrier Transicold  
700 Olympic Drive  
Athens, GA 30601 USA

Central America and Mexico  
Carrier Transicold  
Ejercito Nacional 253-A Piso 5  
Colonia Anahuac 11320 Mexico D.F.