



Carrier Transicold Division  
Carrier Corporation  
P.O. Box 4805  
Syracuse, New York 13221

THIS DOCUMENT AND THE INFORMATION CONTAINED THEREIN IS PROPRIETARY TO CARRIER CORPORATION AND SHALL NOT BE USED OR DISCLOSED TO OTHERS, IN WHOLE OR IN PART, WITHOUT THE WRITTEN AUTHORIZATION OF CARRIER CORPORATION.

SUBMISSION OF THESE DRAWINGS OR DOCUMENTS DOES NOT CONSTITUTE PART PERFORMANCE OR ACCEPTANCE OF CONTRACT

# CROSS REFERENCE INDEX

DESCRIPTION	INSTALLATION DRAWING NO.	KIT NO.
FUEL TANKS (22" DIAMETER)	98-02201	76-00295-XX
LED LIGHT BAR INSTALLATION INSTRUCTIONS	98-03246	76-02000-03
DECAL KIT: ENGLISH - ARABIC	98-03346	76-02033-01
DECAL KIT: ENGLISH - CHINESE	98-03349	76-02033-04
REMOTE EVAPORATOR INSTALLATION KIT (2 COMP)	98-03339	76-02067-00
REMOTE EVAPORATOR INSTALLATION KIT (3 COMP)	98-03339	76-02067-01

KIT NO.	INSTALLATION DRAWING NO.	MODEL DESCRIPTION
76-02066-01	98-02593	VECTOR 8600MT TIER4 (NDK), 2 & 3 COMPARTMENT MUTI-TEMP DOMESTIC

Ⓒ

Ⓒ

Ⓒ

Ⓒ

Ⓒ

## NOTES:

- 1.0 COMPLETE INSTALLATION INCLUDES AND IS NOT LIMITED TO:
  - 1.1 UNIT INSTALLATION
  - 1.2 BATTERY INSTALLATION, INCLUDING DRAIN HOSE
  - 1.3 COMPLETION OF PRE-DELIVERY INSPECTION(PDI) PER MODEL
    - 1.3.1 UNIT PREP AND INITIAL ADJUSTMENTS
    - 1.3.2 CHECKLIST
    - 1.3.3 UNIT RUN IN PER PDI CHECKLIST
    - 1.2.4 WARRANTY REGISTRATION CARD SUBMITTAL
  - 1.4 DEFROST LINE ROUTING AND CLAMPING
  - 1.5 FUEL LINE CONNECTIONS TO UNIT
- 2.0 THE TRAILER OR BOXCAR STRUCTURE MUST BE EVALUATED BY THE TRAILER OR BOXCAR MANUFACTURER TO DETERMINE IT'S ABILITY TO WITHSTAND THE LOADS IMPOSED BY THE UNIT OVER IT'S SERVICE LIFE. CARRIER TRANSICOLD DOES NOT CONVEY ANY ENDORSEMENT OR WARRANTY FOR THE TRAILER'S OR BOXCAR'S STRUCTURAL INTEGRITY.
 

WEIGHTS:  
VECTOR 8600MT REEFER UNIT (WET, LESS BATTERY): 1820 LBS [826 kg]  
VECTOR 8600MT REEFER UNIT W/EES (WET, LESS BATTERY): 1865 LBS [846 kg]  
BATTERY (TYPICAL): 80 LBS [36kg] MAXIMUM
- 3.0 UNIT MOUNTING SURFACES OF THE TRAILER OR BOXCAR THAT CONTACT THE UNIT MOUNTING PADS MUST BE UNI-PLANAR TO WITHIN 0.13 [3] TO PREVENT DISTORTION OF THE UNIT AND/OR TRAILER.
- 4.0 TRAILER OR BOXCAR SURFACES THAT CONTACT THE UNIT MOUNTING GASKET SHOULD NOT PROTRUDE MORE THAN 0.19 [5] ABOVE THE PLANE DEFINED BY THE MOUNTING PAD SURFACES TO ENSURE PROPER AIR SEAL.
- 5.0 ALL DIMENSIONS SHOWN ARE IN INCHES, WITH THE METRIC CONVERSIONS IN [MILLIMETERS].
- Ⓒ 6.0 PRE-DELIVERY INSPECTION AND WARRANTY REGISTRATION DOCUMENTS ARE SHIPPED WITH UNIT AND ARE LOCATED IN THE SIDE DOOR POCKET WITH UNIT MANUAL AND SCHEMATIC.

## Ⓒ ATTENTION:

IF INSTALLING REMOTE EVAPORATOR(S) WITH UNIT AN ADDITIONAL 2 LBS OF REFRIGERANT NEEDS TO BE ADDED TO THE REFRIGERATION SYSTEM FOR IT TO OPERATE PROPERLY. BRINGING THE TOTAL REFRIGERANT CHARGE TO 18 LBS.

IF OPERATING AS A SINGLE TEMPERATURE UNIT (NO REMOTE EVAPORATORS) NO ADDITIONAL REFRIGERANT IS REQUIRED.

Ⓒ

CONTENTS	SHEET
GENERAL INFORMATION	1
SWING RADIUS	2
UNIT DIMENSIONAL DATA	2
EVAP. BACK PANEL: TRAILER OR RAIL	3
TRAILER OR BOXCAR PREPARATION	4
UNIT INSTALLATION	5
UNIT LIFTING LOCATION	5
BATTERY INSTALLATION	6 & 7
STAND BY POWER PLUG INSTALLATION	8
BOTTOM PANEL	9

SYM	REVISION RECORD	DATE	BY	ENGR.	M.E.	NPCA NO.
C	UPDATED SHEET INDEX. ADDED NOTES 6.0, ATTENTION NOTE FOR REFRIGERANT, SHT.9, DECAL KITS, REMOTE EVAP INSTALL KITS AND INSTALLATION KIT P/N TO CHARTS.	28 MAR 2017	ZMG			72N0217P17
B	UPDATED SHEET INDEX. SEE SHEET 7.	19 JUN 2015	LT-SJ			72N0051P14
A	ADDED IN NOTE 2.0: VECTOR 8600MT REEFER UNIT (WET, LESS BATTERY): 1865 LBS [846 kg]	31 OCT 2013	BJM			72N0153P13
-	INITIAL RELEASE.	14 MAR 2013	LT-NM			72N0560P12

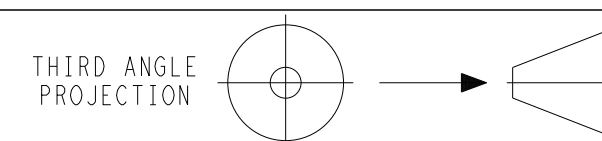

IMPERIAL INCH FORMAT:  
UNLESS OTHERWISE SPECIFIED  
DIMENSIONS ARE IN INCHES WITH  
METRIC CONVERSIONS IN [MILLIMETERS]

TITLE  
INSTALLATION INSTRUCTIONS  
TRAILERS: 2 & 3 COMPARTMENT MUTI-TEMP VECTOR 8600MT

DRAWING NO. 98-02593  
SHEET 1 of 9  
REV C

SHEET INDEX	REV	C	-	-	-	C	-	B	-	C
SHEET	1	2	3	4	5	6	7	8	9	

SEE SEPARATE PARTS LIST

SUPERSEDES:

PART CLASSIFICATION: US EAR99

DRAWING CLASSIFICATION: US EAR99



Carrier Transicold Division  
Carrier Corporation  
P.O. Box 4805  
Syracuse, New York 13221

THIS DOCUMENT AND THE INFORMATION CONTAINED THEREIN IS PROPRIETARY TO CARRIER CORPORATION AND SHALL NOT BE USED OR DISCLOSED TO OTHERS, IN WHOLE OR IN PART, WITHOUT THE WRITTEN AUTHORIZATION OF CARRIER CORPORATION.

SUBMISSION OF THESE DRAWINGS OR DOCUMENTS DOES NOT CONSTITUTE PART PERFORMANCE OR ACCEPTANCE OF CONTRACT

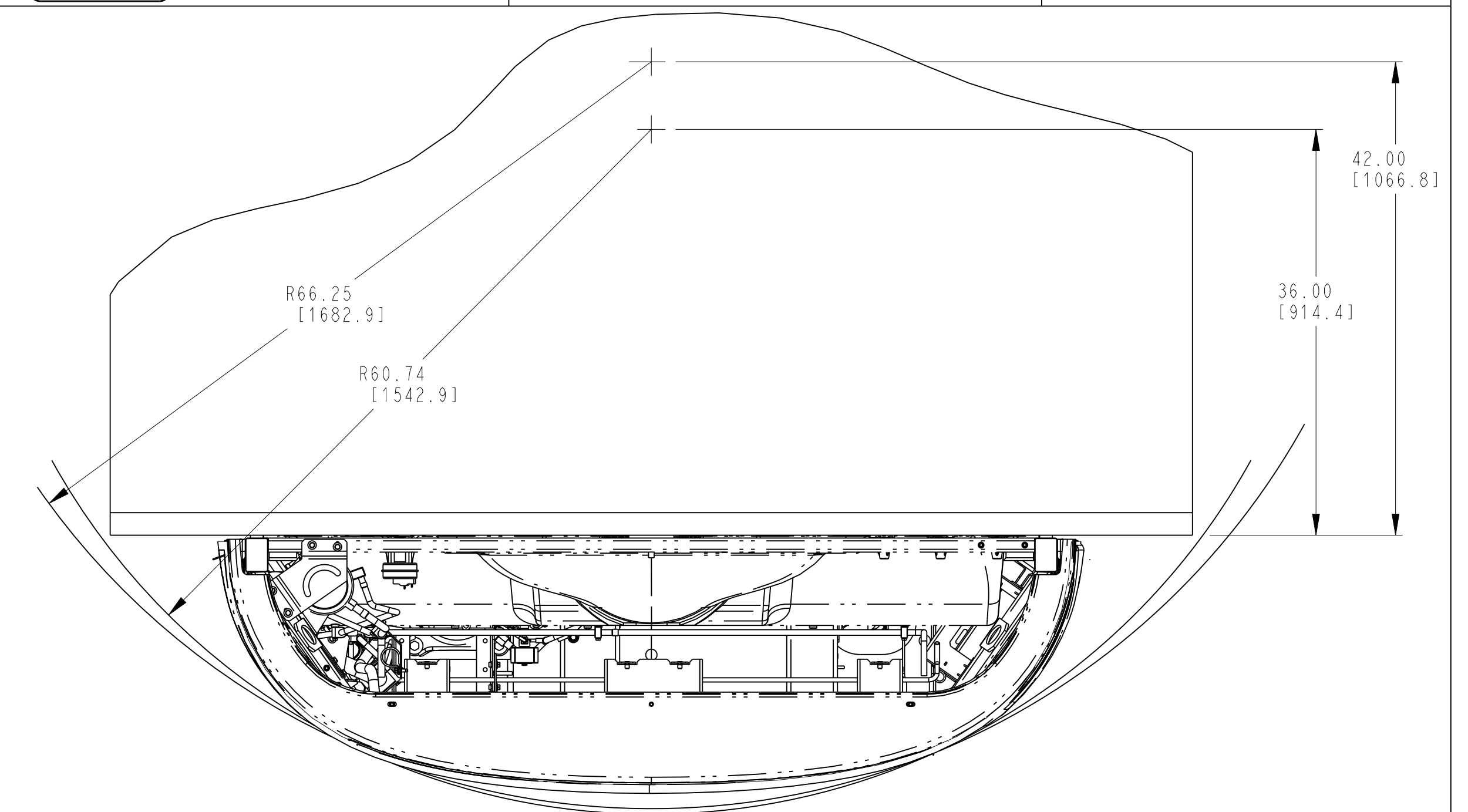
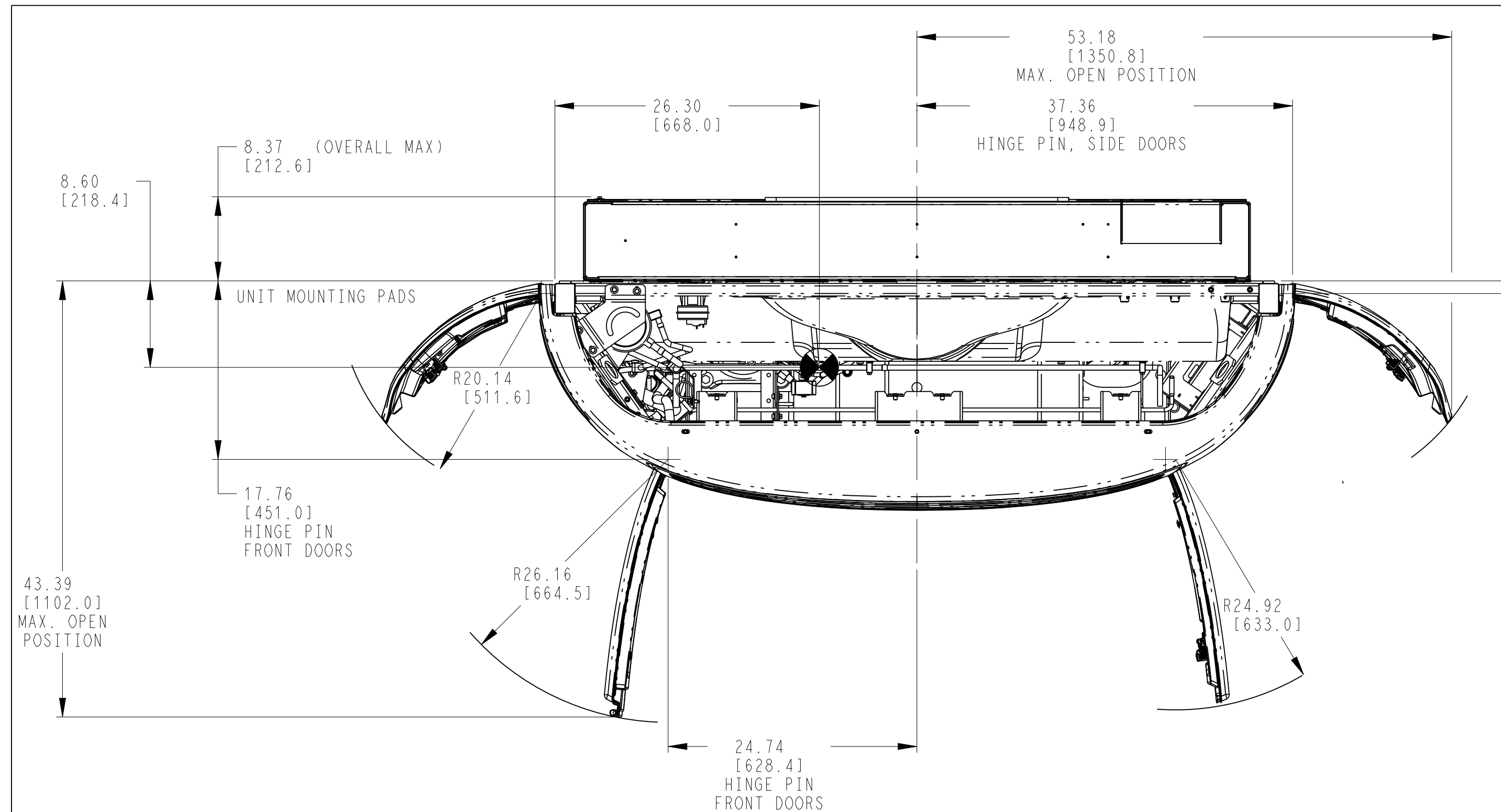

### SWING RADIUS

ALL UNIT VERSIONS

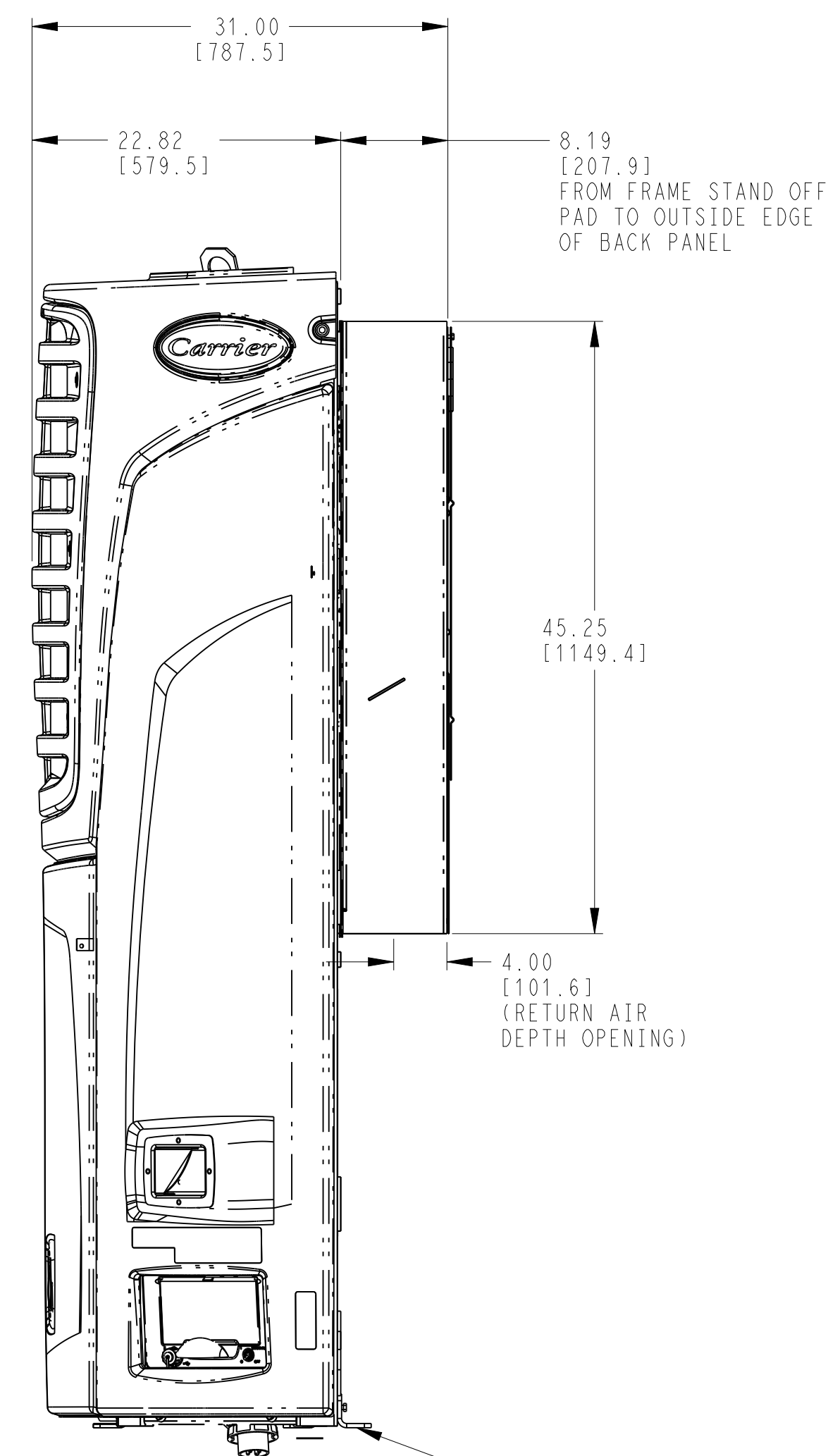
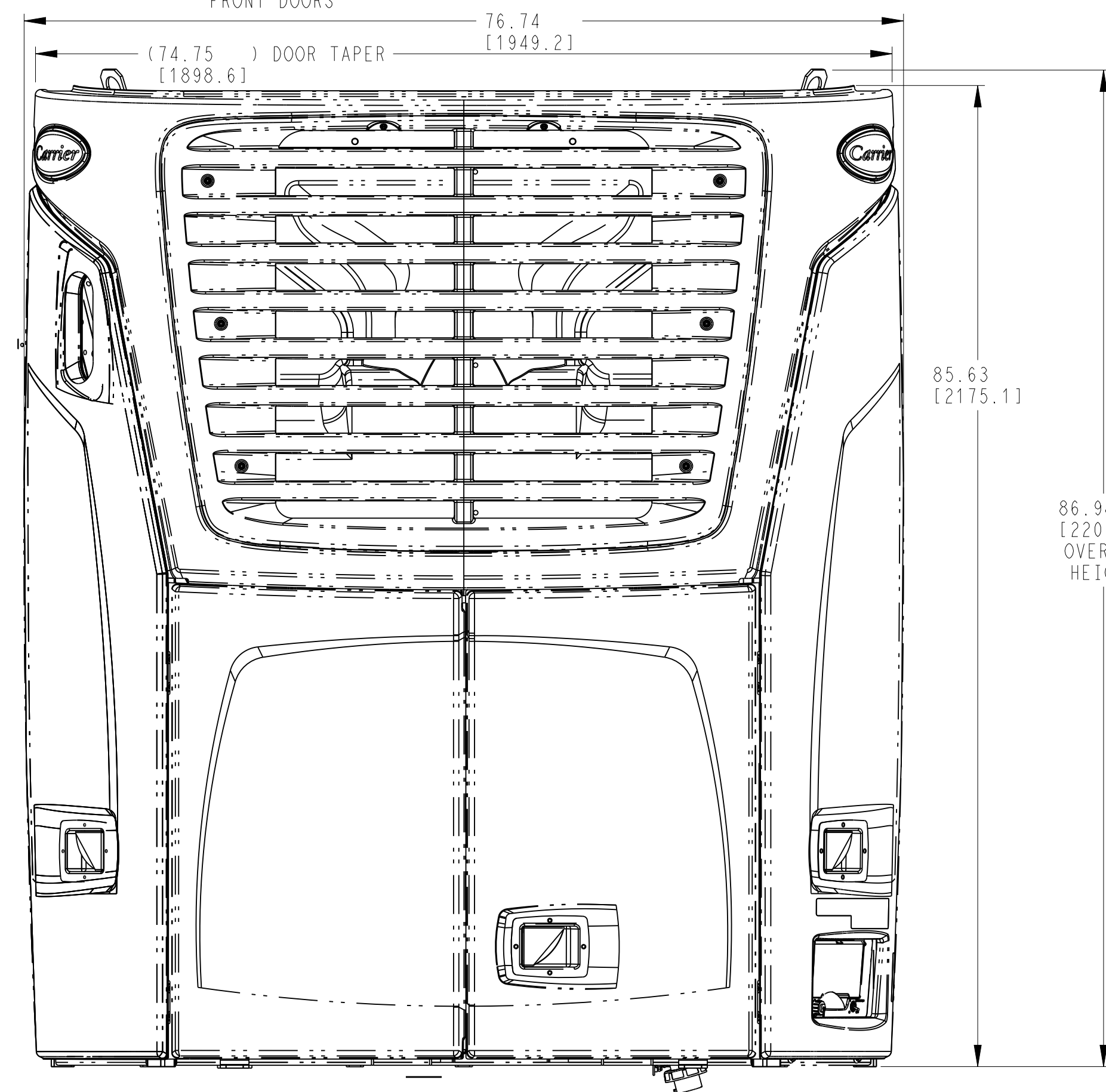

### UNIT DIMENSION INFORMATION

ALL UNIT VERSIONS

PALLET MOUNTING ANGLE. REMOVE BEFORE INSTALLING UNIT.

-	INITIAL RELEASE.	14 MAR 2013	LT-NM			72N0560P12
SYM	REVISION RECORD	DATE	BY	ENGR.	M.E.	NPCA NO.

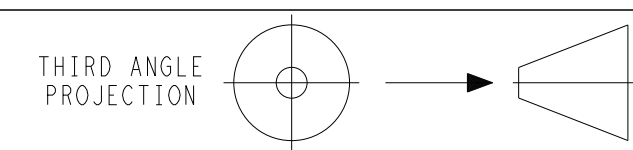

IMPERIAL INCH FORMAT:  
UNLESS OTHERWISE SPECIFIED  
DIMENSIONS ARE IN INCHES WITH  
METRIC CONVERSIONS IN [MILLIMETERS]

TITLE  
INSTALLATION INSTRUCTIONS  
TRAILERS: 2 & 3 COMPARTMENT MUTI-TEMP VECTOR 8600MT

DRAWING NO.	98-02593	REV	-
		SHEET 2 OF	

SUPERSEDES:

PART CLASSIFICATION: US EAR99

DRAWING CLASSIFICATION: US EAR99

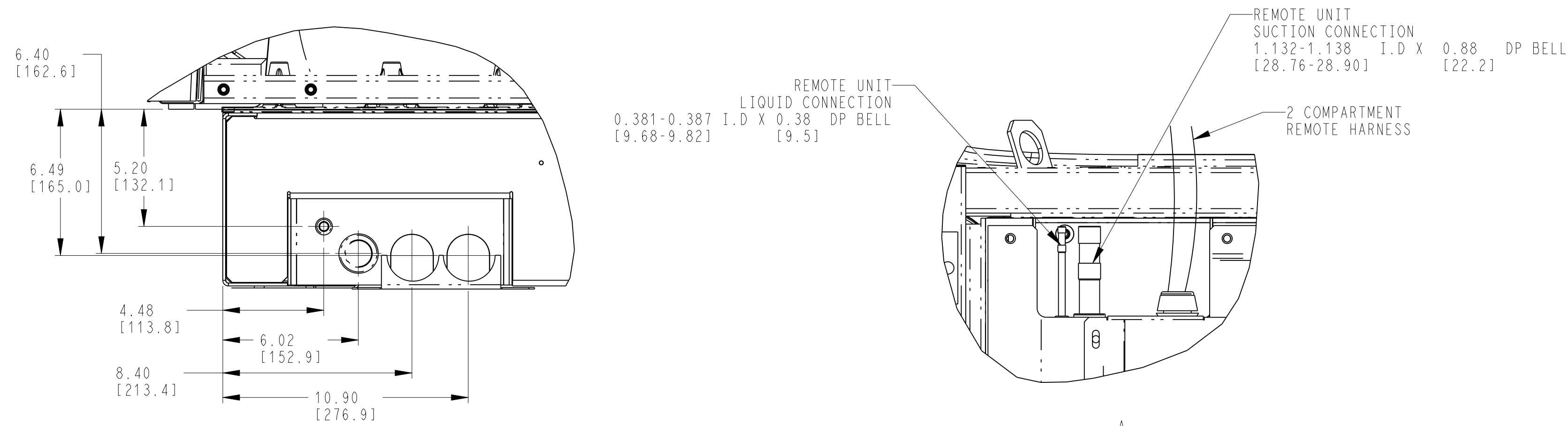

DETAIL A 2CPT  
 SCALE 0.200

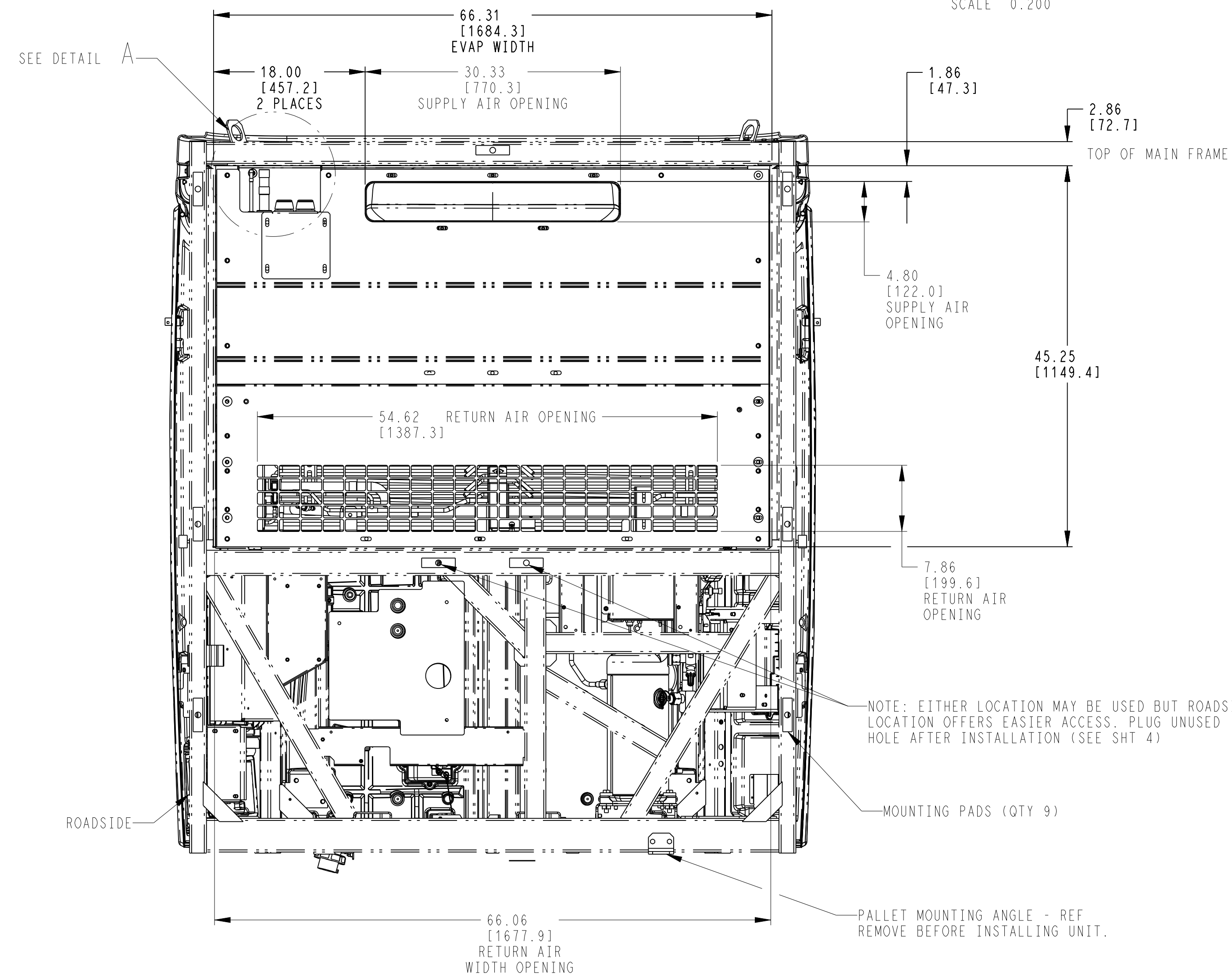

REAR VIEW : WITH UPPER AND LOWER BACK PANELS

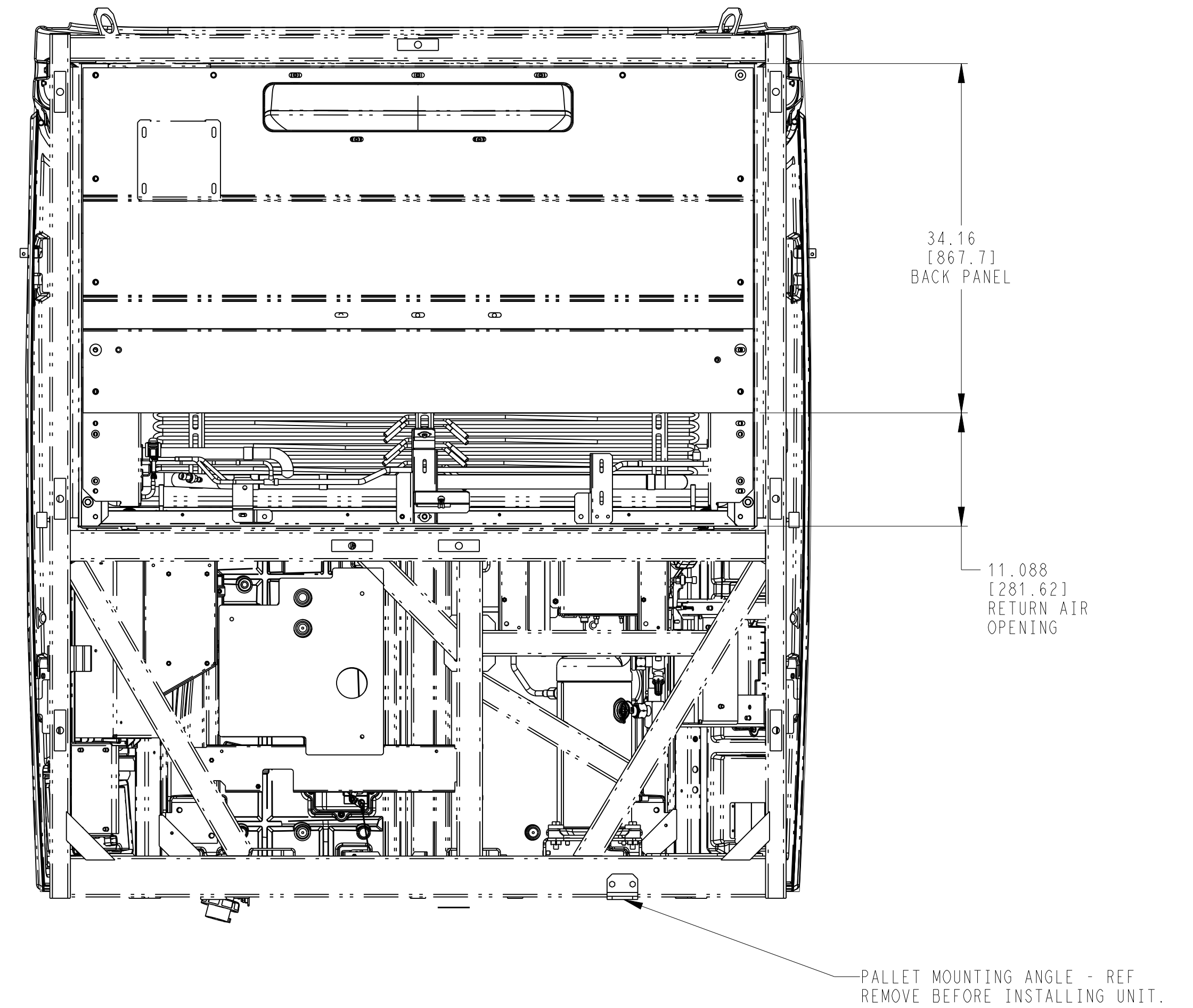

REAR VIEW : UPPER BACK PANEL ONLY

INITIAL RELEASE.	24 MAR 2013	LT-NM			72N0560P12	THIRD ANGLE PROJECTION	IMPERIAL INCH FORMAT: UNLESS OTHERWISE SPECIFIED DIMENSIONS ARE IN INCHES WITH METRIC CONVERSIONS IN (MILLIMETERS)	TITLE	DRAWING NO.	REV
REVISION RECORD	DATE	BY	ENGR.	M.E.	NPCA NO.			INSTALLATION INSTRUCTIONS TRAILERS: 2 & 3 COMPARTMENT MULTI-TEMP VECTOR 8600MT	98-02593	-
								SHEET 3 OF		

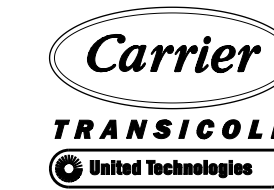

Carrier Transicold Division  
Carrier Corporation  
P.O. Box 4805  
Syracuse, New York 13221

THIS DOCUMENT AND THE INFORMATION CONTAINED THEREIN IS PROPRIETARY TO CARRIER CORPORATION AND SHALL NOT BE USED OR DISCLOSED TO OTHERS, IN WHOLE OR IN PART, WITHOUT THE WRITTEN AUTHORIZATION OF CARRIER CORPORATION.

SUBMISSION OF THESE DRAWINGS OR DOCUMENTS DOES NOT CONSTITUTE PART PERFORMANCE OR ACCEPTANCE OF CONTRACT

# TRAILER OR BOXCAR BODY PREPARATION

**CAUTION:** UNIT MOUNTING SURFACES OF TRAILER OR BOXCAR THAT CONTACT THE UNIT MOUNTING PADS MUST BE UNI-PLANAR TO WITHIN 0.13[3] TO PREVENT DISTORTION OF UNIT AND/OR TRAILER/BOXCAR.

**CAUTION:** TRAILER OR BOXCAR SURFACES THAT CONTACT THE UNIT MOUNTING GASKET SHOULD NOT PROTRUDE MORE THAN 0.19[5] ABOVE THE PLANE DEFINED BY THE MOUNTING PAD SURFACES TO ENSURE PROPER AIR SEAL.

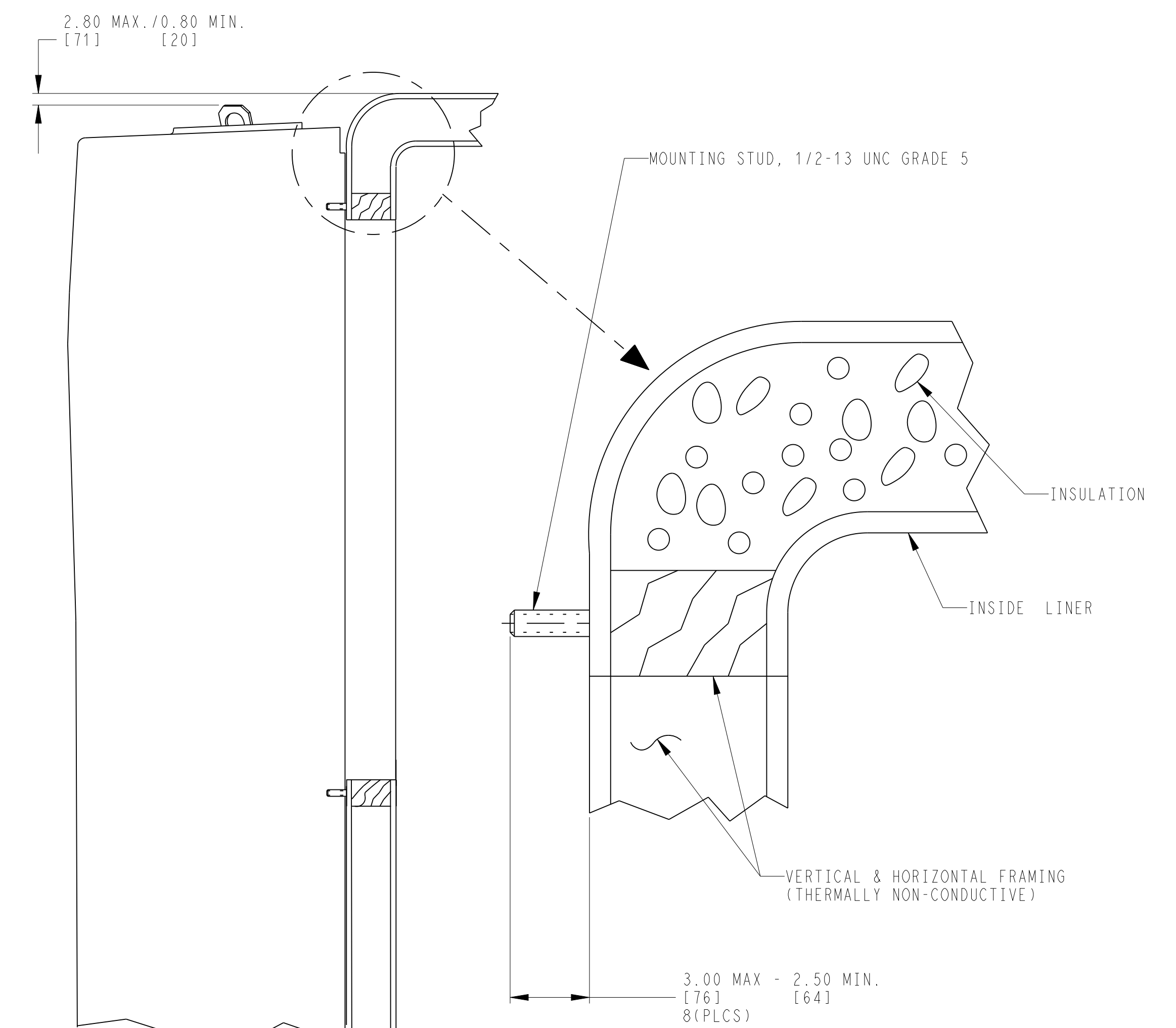
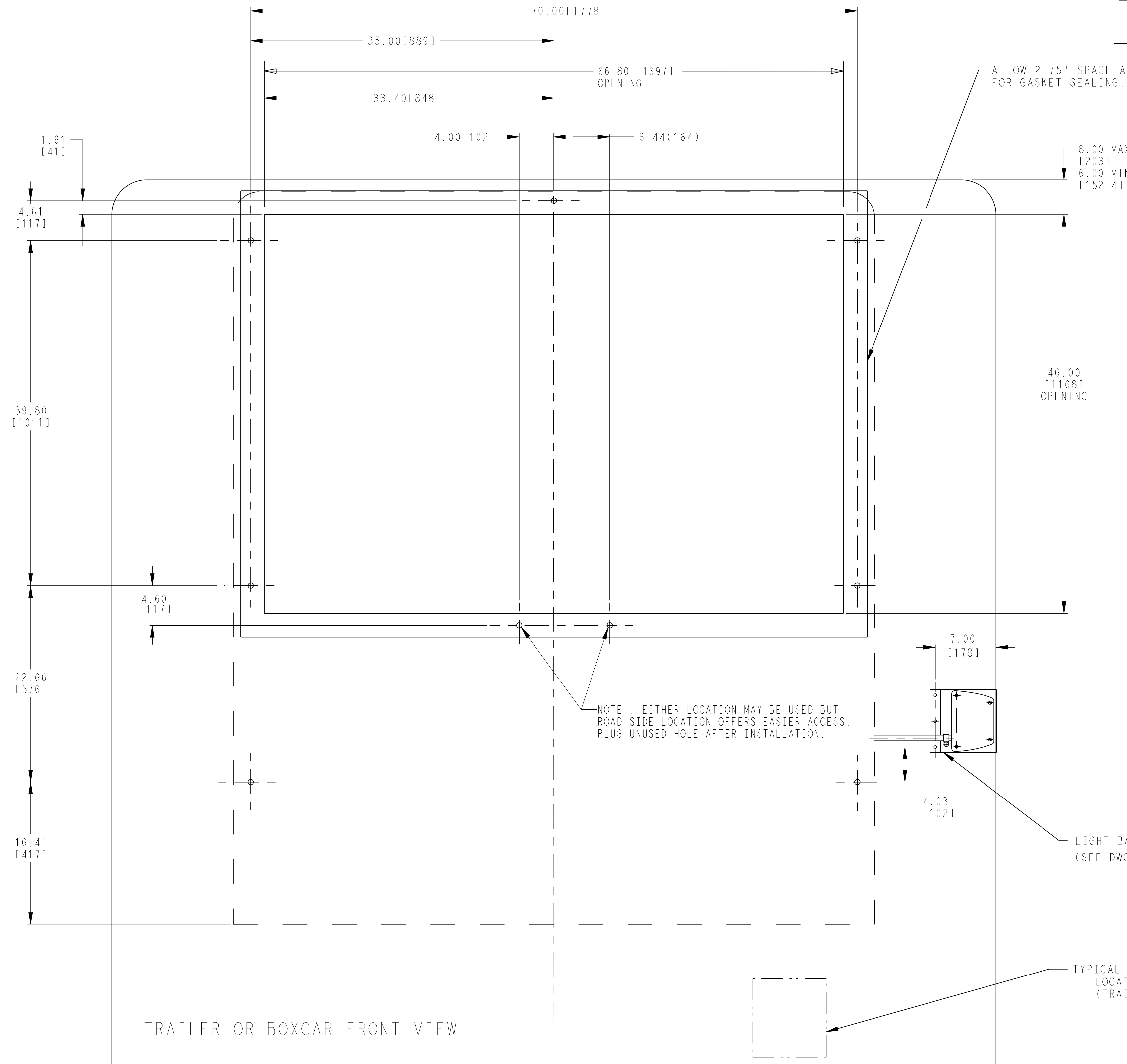

TRAILER SIDE VIEW

TRAILER OR BOXCAR FRONT VIEW

-	INITIAL RELEASE.	14 MAR 2013	LT-NM			72N0560P12	THIRD ANGLE PROJECTION	IMPERIAL INCH FORMAT: UNLESS OTHERWISE SPECIFIED DIMENSIONS ARE IN INCHES WITH METRIC CONVERSIONS IN [MILLIMETERS]	TITLE INSTALLATION INSTRUCTIONS TRAILERS: 2 & 3 COMPARTMENT MUTI-TEMP VECTOR 8600MT	DRAWING NO. 98-02593 SHEET 4 OF	REV -
SYM	REVISION RECORD	DATE	BY	ENGR.	M.E.	NPCA NO.			SUPERSEDES:	PART CLASSIFICATION: US EAR99	

DRAWING CLASSIFICATION: US EAR99

NOTE: BULKHEAD, AIR CHUTE AND TRANSITION DUCT SHOWN ARE OPTIONAL FEATURES. FOR BEST AIR CIRCULATION AND PRODUCT PROTECTION CARRIER TRANSCOLD HIGHLY RECOMMENDS THE USE OF BULKHEADS AIR CHUTES AND TRANSITION DUCTS. CONTACT YOUR DEALER OR CARRIER TRANSCOLD FOR RECOMMENDATIONS.

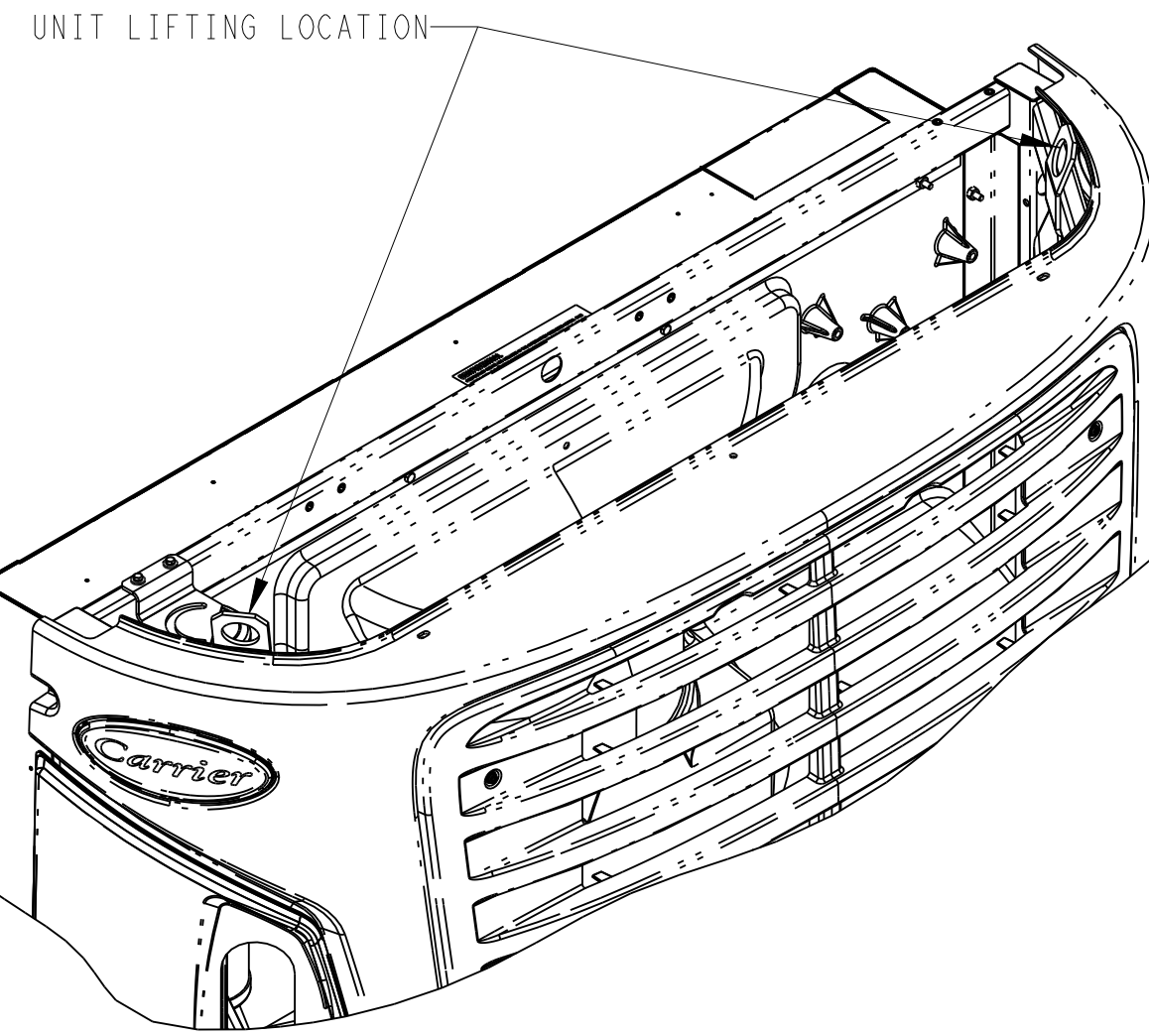

PREPARE UNIT FOR INSTALLATION:

- 1.0 PREPARE THE BODY TO RECEIVE THE UNIT. DIMENSIONS FOR EVAPORATOR OPENING AND MOUNTING STUD LOCATIONS CAN BE FOUND ON SHEET 4 OF THIS DRAWING.
- 2.0 REMOVE WIRE TIES HOLDING DEFROST DRAIN HOSES, COOLANT OVERFLOW TUBE, AND FUEL LINES. PLACE LINES WHERE THEY WILL NOT BE CAUGHT BETWEEN THE UNIT FRAME AND THE MOUNTING SURFACE. REMOVE PALLET MOUNTING ANGLE ON BACK BOTTOM OF FRAME.
- 3.0 OPEN SIDE DOORS TO ALLOW ACCESS TO MOUNTING STUD LOCATIONS ON UNIT.
- 4.0 INSTALL BATTERY ACCORDING TO INSTRUCTIONS ON SHEETS 6 & 7. IF UNIT HAS BEEN SUPPLIED WITH BATTERY, CONNECT BATTERY CABLES ACCORDING TO THE INSTRUCTIONS ON SHEETS 6 & 7.
- 5.0 PREPARE THE UNIT FOR LIFTING: STANDING ON A LADDER OR WORK-STAND, HOOK LIFTING APPARATUS (LIFTING SPREADER BAR WITH SUFFICIENT CAPACITY TO SUPPORT UNIT AND BATTERY) THROUGH THE LIFTING EYES. LIFT POINT SHOULD BE CENTERED OVER THE UNIT.

UNIT INSTALLATION:

- 6.0 RAISE THE UNIT AND INSTALL IN THE BODY OPENING. ENSURE THAT ALL EIGHT STUDS ARE FULLY ENGAGED IN THE UNIT FRAME. PLACE WASHER (ITEM 70) AND LOCK-NUT (ITEM 45) ON EACH OF THE 8 STUDS. (NOTE: THE LOWER CENTER STUD MUST BE ACCESSED FROM THE FRONT OF THE UNIT.) SNUG THE NUTS, THEN EVENLY TIGHTEN ALL EIGHT TO 60 FT-LB/81.6 NM USING A TORQUE WRENCH. REMOVE LIFTING APPARATUS.
- 7.0 INSTALL BUTTON PLUGS (ITEM 92) IN UNIT FRAME WHERE MOUNTING STUDS ARE LOCATED AND ADDITIONAL UNUSED HOLE (SEE SHT.2).
- 8.0 ROUTE DEFROST DRAIN HOSES DOWN THE FRONT OF THE TRAILER OR BOXCAR AND CLAMP TO FRONT WALL USING 2 CLAMPS (ITEM 15) AND 2 THREAD FORMING SCREWS (ITEM 30) FOR EACH DRAIN HOSE. CUT HOSE TO PROPER LENGTH (APPROXIMATELY 3.00[76.2] ABOVE 5th-WHEEL PLATE ON TRAILER) AND INSTALL KAZOOS (ITEM 90) ON THE HOSES.
- 9.0 INSTRUCTIONS FOR FUEL LINE CONNECTION ARE SUPPLIED WITH THE FUEL TANK KIT. INSTRUCTIONS FOR LIGHT BAR INSTALLATION ARE INCLUDED WITH THE LIGHT BAR KIT.

AFTER INSTALLATION

- 10.0 PERFORM PRE-DELIVERY INSPECTION. COPIES OF COMPLETED CHECKLIST SHOULD BE SUPPLIED TO SELLING DEALER AND CUSTOMER.
- 11.0 OPERATE UNIT IN CONTINUOUS RUN WITH REAR DOORS OPEN (MANUAL) MODE. REFER TO THE PRE-DELIVERY INSPECTION FORM SUPPLIED WITH UNIT FOR THE RECOMMENDED LENGTH OF TIME. PERFORM FINAL INSPECTION ON UNIT. RUN- IN SET UP SHOULD BE "PER PDI SHEET".
- 12.0 IMPORTANT: PRIOR TO FINAL DELIVERY TO CUSTOMER, WARRANTY REGISTRATION MUST BE COMPLETED. ONE COPY SHOULD BE PROVIDED TO THE CUSTOMER, ONE COPY TO THE SELLER, AND THE FINAL COPY MUST BE SENT TO CARRIER TRANSCOLD. IN-SERVICE DATE MUST BE STAMPED ON THE UNIT IN THE PROPER LOCATION (SERIAL NUMBER PLATE) TO ACTIVATE WARRANTY COVERAGE.
- 13.0 OPTIONAL BULKHEAD CONFIGURATION: HOLE PATTERN OR OPEN AREA FOR RETURN AIR FLOW MUST TOTAL AT LEAST 2.75 SQ.FT. OF AIR PASSAGE. HOLE PATTERN OR OPEN AREA MUST BE RECESSED SO THAT CARGO LOADED AGAINST BULKHEAD WILL NOT OBSTRUCT AIR PASSAGE OPENINGS. PERFORATED BULKHEADS, THAT MEET THESE REQUIREMENTS, MAY BE INSTALLED TIGHT WITH FLOOR.

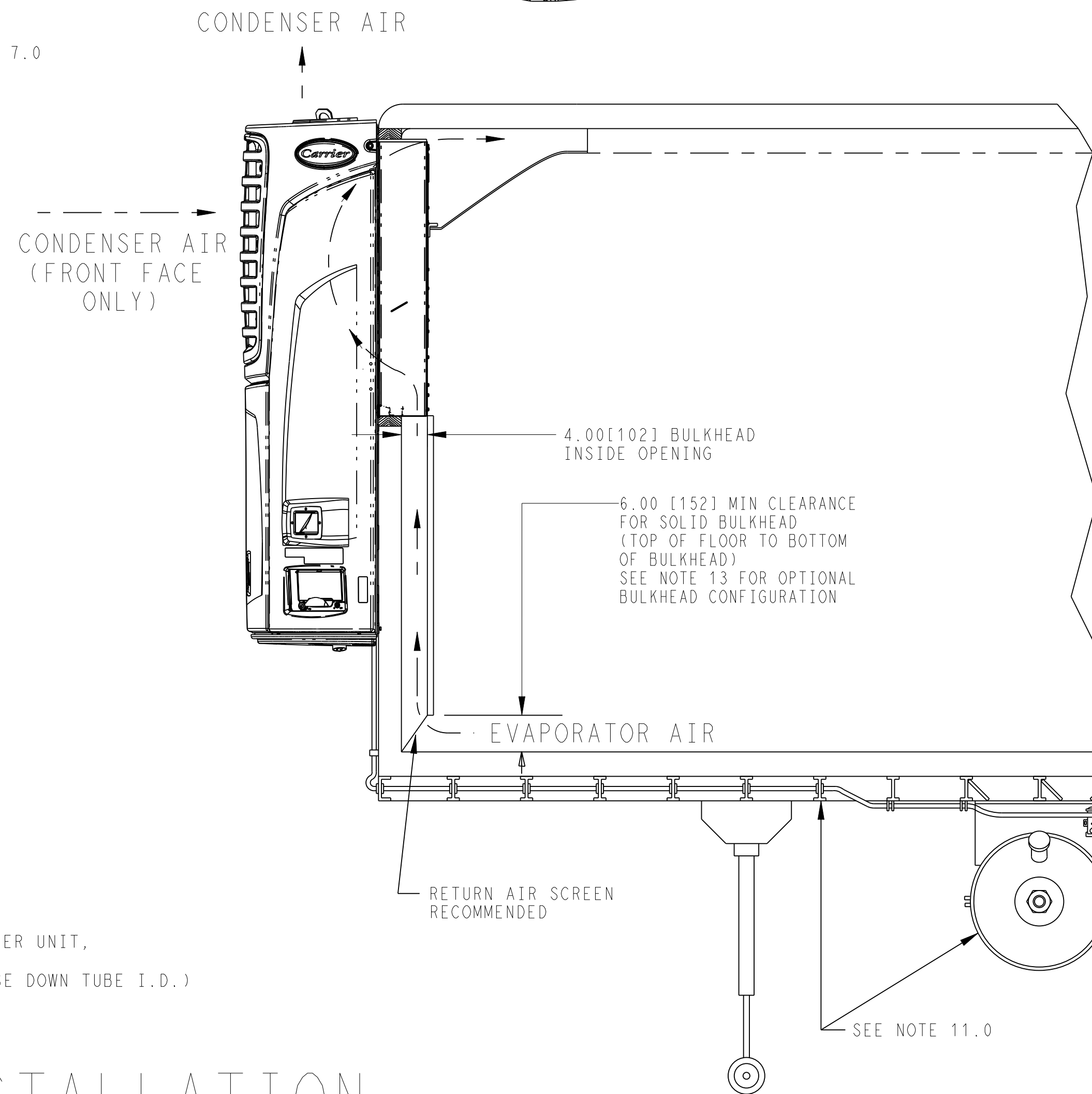
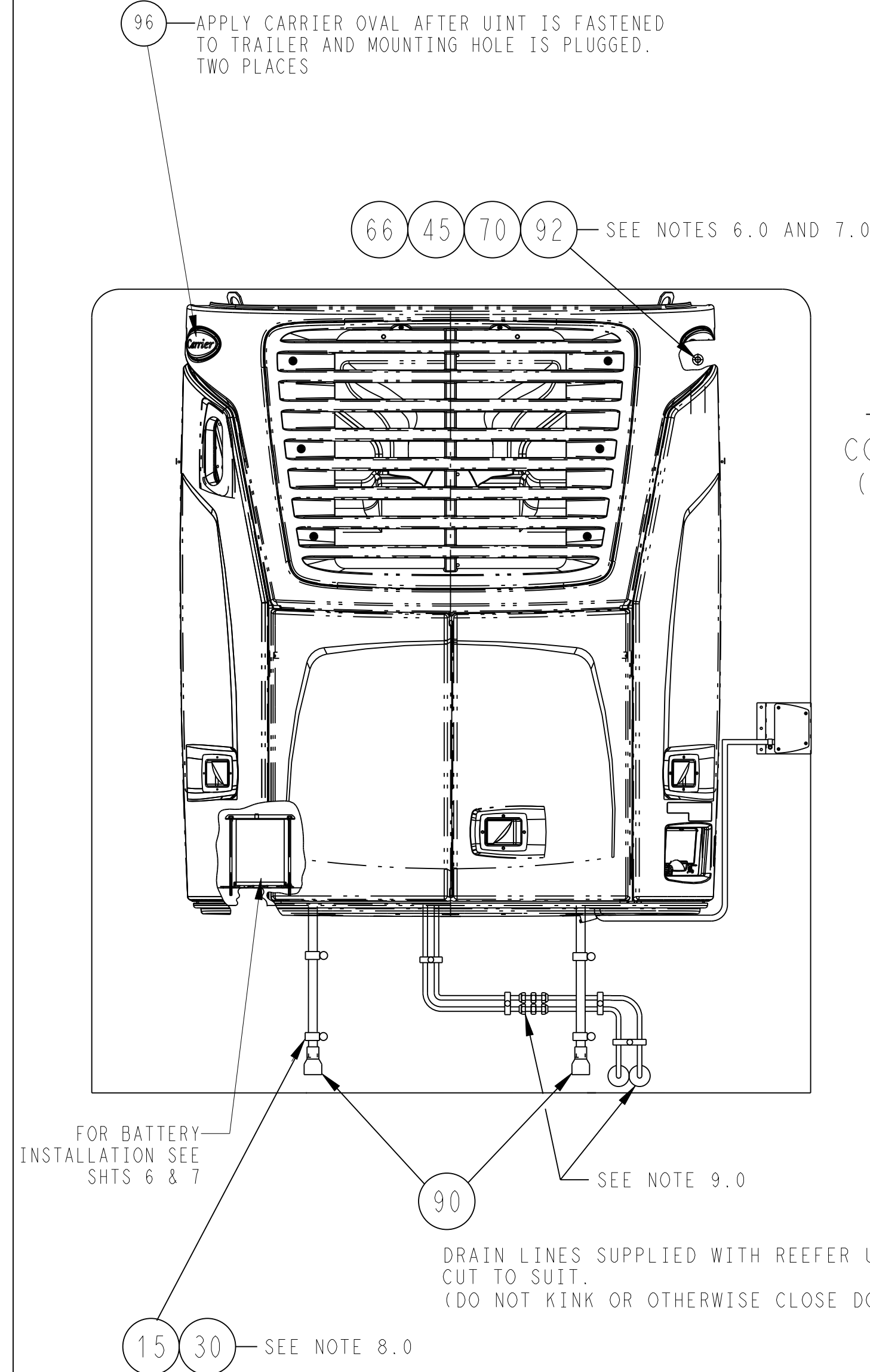

# UNIT INSTALLATION

C	REVISED NOTES 10.0, 11.0 AND 12.	28 MAR 2017	ZMG			72N0217P17
-	INITIAL RELEASE.	14 MAR 2013	LT-NM			72N0560P12
SYM	REVISION RECORD	DATE	BY	ENGR.	M.E.	NPCA NO.

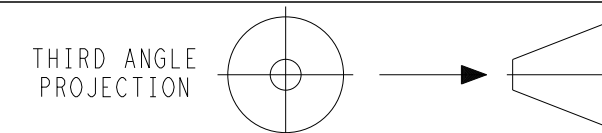

IMPERIAL INCH FORMAT:  
UNLESS OTHERWISE SPECIFIED  
DIMENSIONS ARE IN INCHES WITH  
METRIC CONVERSIONS IN [MILLIMETERS]

TITLE  
INSTALLATION INSTRUCTIONS  
TRAILERS: 2 & 3 COMPARTMENT MUTI-TEMP VECTOR 8600MT

DRAWING NO.	98-02593	REV	C
	SHEET 5 OF		



Carrier Transicold Division  
Carrier Corporation  
P.O. Box 4805  
Syracuse, New York 13221

THIS DOCUMENT AND THE INFORMATION CONTAINED THEREIN IS PROPRIETARY TO CARRIER CORPORATION AND SHALL NOT BE USED OR DISCLOSED TO OTHERS, IN WHOLE OR IN PART, WITHOUT THE WRITTEN AUTHORIZATION OF CARRIER CORPORATION.

SUBMISSION OF THESE DRAWINGS OR DOCUMENTS DOES NOT CONSTITUTE PART PERFORMANCE OR ACCEPTANCE OF CONTRACT

# BATTERY INSTALLATION INSTRUCTIONS

SEE NEXT SHEET FOR PICTORIALS OR REFER TO BATTERY INSTALLATION DOCUMENT IN POLY BAG FASTENED TO BATTERY TRAY PLATE.

## UNITS SUPPLIED WITH BATTERY INSTALLED

- 1.0 CUT WIRE TIE(S) THAT HOLD BATTERY CABLES TO UNIT FRAME.
- 2.0 CONNECT RED BATTERY CABLE TO THE POSITIVE (+) BATTERY TERMINAL; CONNECT BLACK CABLE TO NEGATIVE (-) BATTERY TERMINAL (USE OF CORROSION INHIBITOR IS RECOMMENDED).
- 3.0 POSITION TERMINAL COVERS SUPPLIED WITH CABLES OVER TERMINALS.

## UNITS SUPPLIED WITHOUT BATTERY INSTALLED

- 1.0 USE THE FOLLOWING INFORMATION TO CORRECTLY SELECT THE BATTERY PERFORMANCE NEEDED FOR REFRIGERATION UNITS.

GROUP SIZE: GROUP 31  
VENT LOCATION: SIDE VENT  
VOLTS: 12 VOLTS DC  
AMPERAGE: MINIMUM 700 COLD CRANKING AMPS @ 0°F  
MINIMUM 545 COLD CRANKING AMPS @ -20°F

NOTE: WHEN SELECTING A SPECIFIC BRAND OF BATTERY, ALWAYS ENSURE THAT THE BATTERY CHOSEN IS RATED AT 0°F (0 DEGREES FAHRENHEIT) AND NOT 0°C (0 DEGREES CELSIUS). FAILURE TO USE THE PROPER BATTERY SIZE WILL RESULT IN REDUCED BATTERY LIFE AND A NO-START CONDITION. THE RECOMMENDED MAXIMUM BATTERY WEIGHT IS 80 LBS.

- 2.0 CUT WIRE TIE HOLDING THESE PARTS IN THE BATTERY TRAY AND REMOVE PARTS. PLACE BATTERY IN TRAY WITH POSITIVE (+) TERMINAL TO THE REAR OF THE UNIT (AS SHOWN). CONNECT BATTERY CABLES (THE USE OF A CORROSION INHIBITOR ON THE TERMINALS IS RECOMMENDED); RED CABLE TO POSITIVE (+) TERMINAL, BLACK CABLE TO THE NEGATIVE (-) TERMINAL. CABLES SHOULD BE ROUTED TOWARD THE COMPRESSOR (AS SHOWN). TIGHTEN TERMINAL CONNECTORS SECURELY.
- 3.0 INSTALL SCREWS AND HOLD-DOWN CHANNEL USING PLAIN AND LOCK WASHERS AS SHOWN. SECURELY TIGHTEN THE SCREWS TO PREVENT MOVEMENT OF THE BATTERY.
- 4.0 POSITION TERMINAL COVERS SUPPLIED WITH CABLES OVER TERMINALS.

-	INITIAL RELEASE.	14 MAR 2013	LT-NM			72N0560P12	THIRD ANGLE PROJECTION		IMPERIAL INCH FORMAT: UNLESS OTHERWISE SPECIFIED DIMENSIONS ARE IN INCHES WITH METRIC CONVERSIONS IN [MILLIMETERS]	TITLE INSTALLATION INSTRUCTIONS TRAILERS: 2 & 3 COMPARTMENT MULTI-TEMP VECTOR 8600MT	DRAWING NO. 98-02593 SHEET 6 OF	REV -
SYM	REVISION RECORD	DATE	BY	ENGR.	M.E.	NPCA NO.						

SUPERSEDES: \_\_\_\_\_

PART CLASSIFICATION: US EAR99

DRAWING CLASSIFICATION: US EAR99

NOTE:

- 1.0 CAUTION: DUE TO DIFFERENT BATTERY MFG. WHEN APPLYING TORQUE TO BATTERY U-BRACKET, MAKE SURE THERE IS NO BATTERY HOUSING DISTORTION OR CRUSHING.
- 2.0 WHEN INSTALLING POSITIVE BATTERY CABLE TO BATTERY POST ENSURE THERE IS CLEARANCE BETWEEN THE CABLE AND THE FRAME.
  - 2.1 VECTOR 8500/8600: 0°
  - 2.2 VECTOR NDKA: 15°
- 3.0 WHEN INSTALLING LEFT J-HOOK INTO L-BRACKET ROTATE OPPOSITE OF RIGHT J-HOOK.

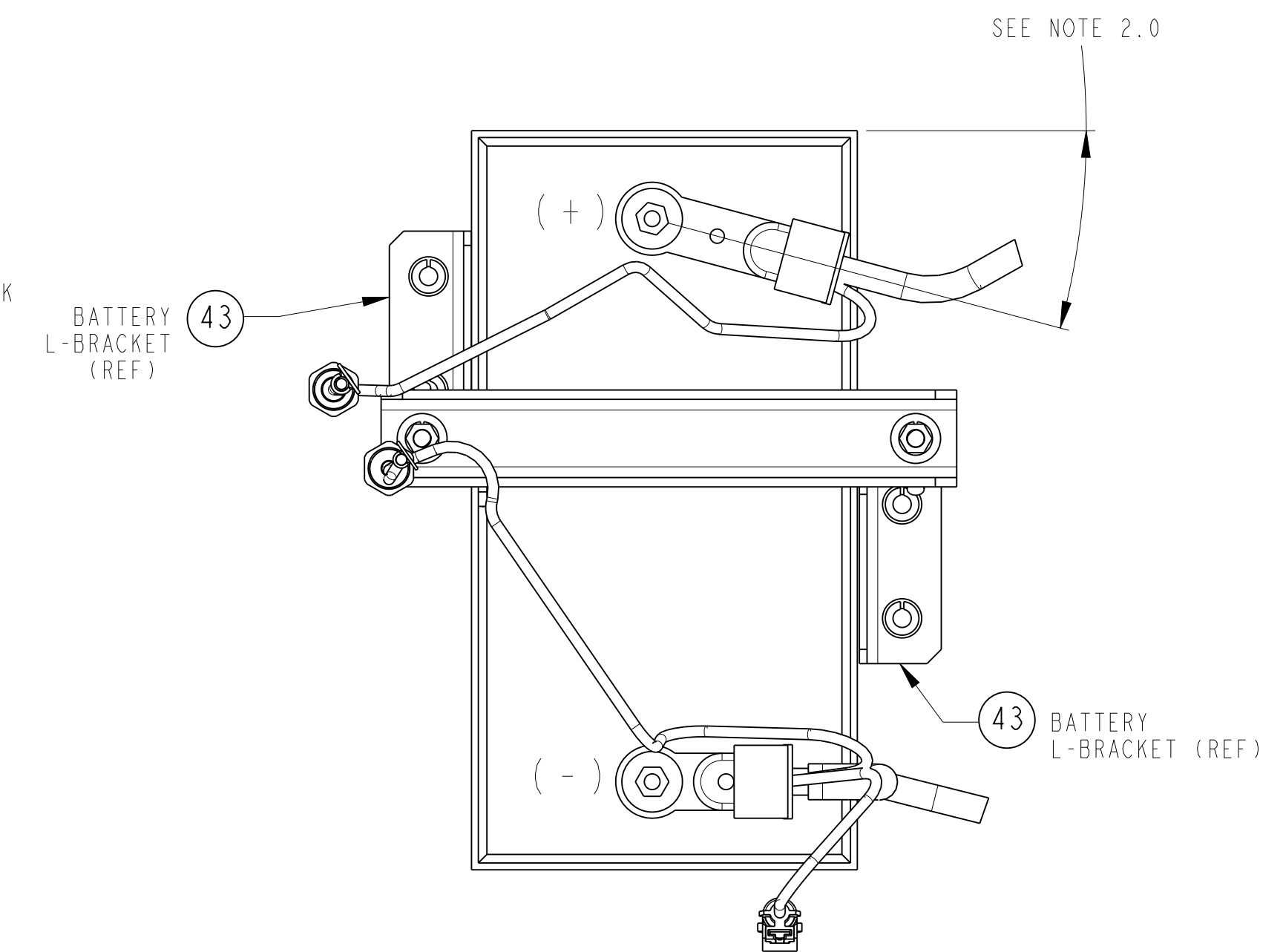
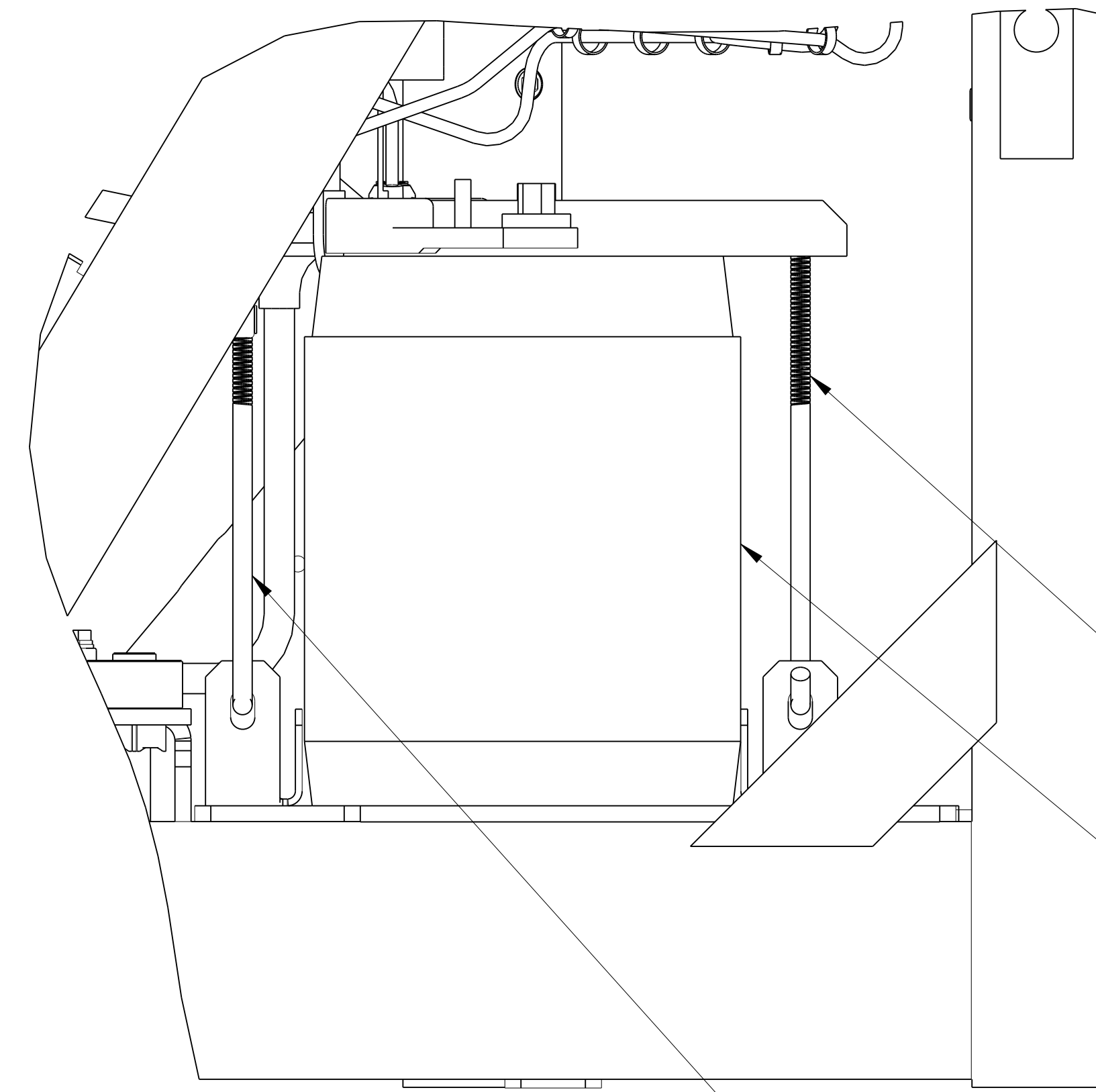
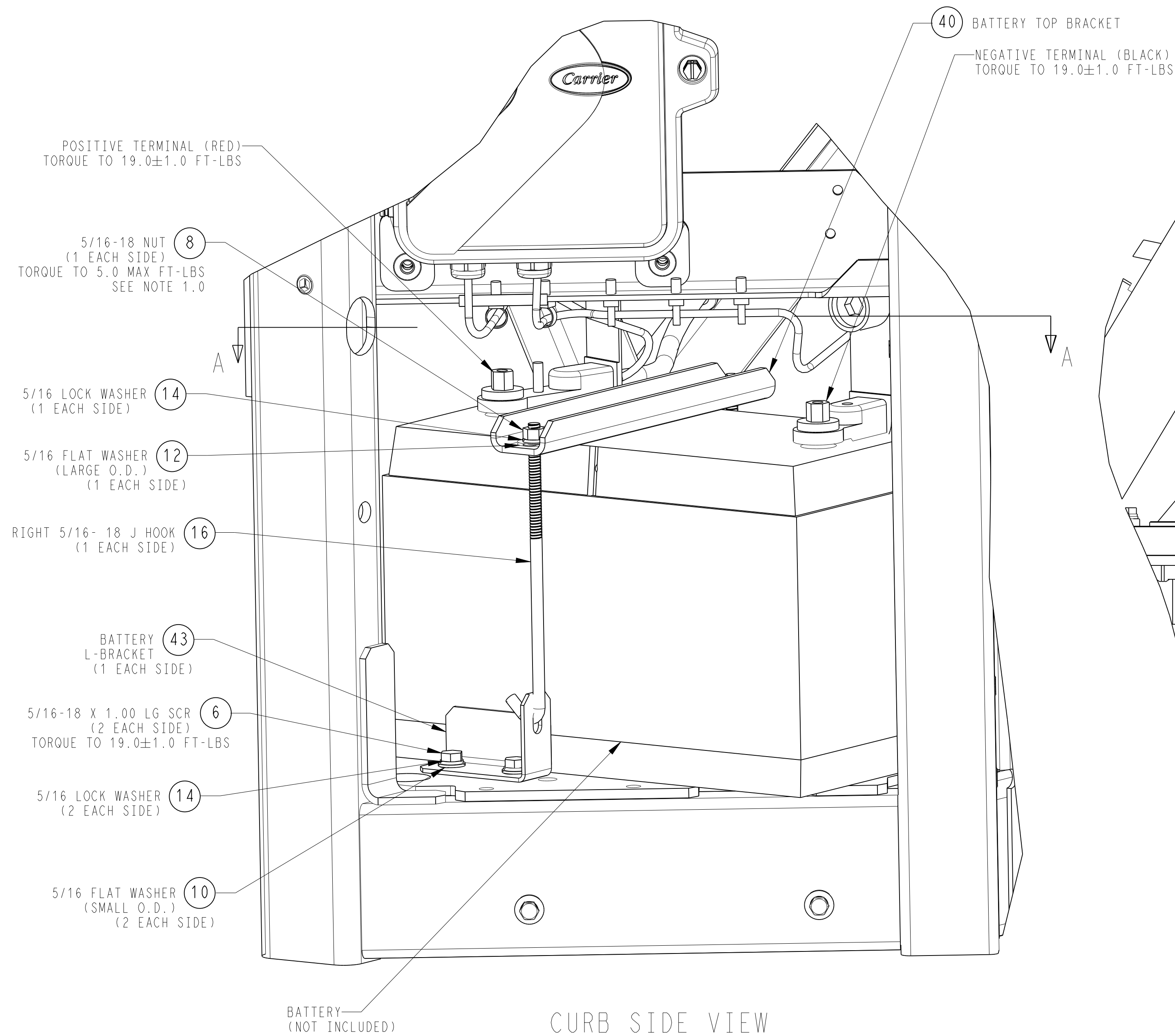

INSTALL BATTERY INTO UNIT WITH POSITIVE (+) TERMINAL TOWARD THE REAR.

### BATTERY INSTALLATION PROCEDURE FOR UNITS SHIPPED WITHOUT BATTERY.

LOCATE BAG STRAPPED TO VERTICAL REAR TUBE NEXT TO BATTERY TRAY AND REMOVE U-BRACKET, L-BRACKETS & MOUNTING HARDWARE.

TOP OF BATTERY TYPICAL CABLE ROUTING FOR: VECTOR 8600  
VIEW A-A BATTERY CABLE ARRANGEMENT.

B	BATTERY INSTALLATION PROCEDURE UPDATED.	19 JUN 2015	LT-SJ			72N0051P14
-	INITIAL RELEASE.	14 MAR 2013	LT-NM			72N0560P12
SYM	REVISION RECORD	DATE	BY	ENGR.	M.E.	NPCA NO.

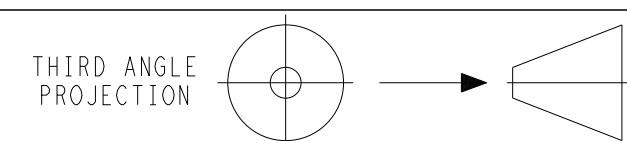

IMPERIAL INCH FORMAT: UNLESS OTHERWISE SPECIFIED DIMENSIONS ARE IN INCHES WITH METRIC CONVERSIONS IN [MILLIMETERS]

TITLE  
INSTALLATION INSTRUCTIONS  
TRAILERS: 2 & 3 COMPARTMENT MULTI-TEMP VECTOR 8600MT

DRAWING NO. 98-02593  
SHEET 7 OF 8  
REV B

## Electrical Specifications & Minimum Standby Infrastructure for Carrier Transicold Trailer units equipped with Standby

	<b>Vector 8600 W/STBY</b>
Operating Voltage	460V / 3ph / 60Hz
Full Load Amp Draw (FLA)	22 A
kVA	18.5
Locked Rotor Amp Draw (LRA)	90 A
Electrical Receptacle (installed on unit)	IEC IP 67 pin & sleeve, 480V, 30A, 4 wire, 3 pole
Receptacle p/n	22-04166-01
Phase reversal	Automatic
<b>Standby circuit breaker &amp; cordset specifications</b>	
Standby cable type & gauge (min 50' long, up to 75' long)	SOOW, 600V, 90C, 10/4 (3ph + G)
Recommended external circuit breaker	30A
Connector p/n	22-02944-00

### Minimum Requirements for Standby Infrastructure

- 1) Ensure that the standby power installation is performed by a licensed electrician who is familiar with both local and national electric codes and requirements.
- 2) Each refrigeration unit must be protected by an individual circuit breaker sized per the appropriate unit electrical specification listed above.
- 3) A continuous earthing ground conductor must be provided at the plug and through the power cord to the refrigeration unit.
- 4) Carrier Transicold recommends that customers establish an Assured Equipment Grounding Conductor Program per the National Electric Code (NEC). Per the Assured Equipment Grounding Conductor Program, the NEC calls for all cordsets to be verified for ground continuity and correct wiring on a 3 month basis.
- 5) A neutral conductor **MUST NOT** be connected to the refrigeration units. All Carrier Transicold refrigeration units are balanced three phase systems; therefore, the unit only requires three phase wires and a ground conductor.
- 6) Standby power cordsets between the circuit breaker and the refrigeration unit **MUST** be constructed from 10/4 SOOW cable. Carrier recommends a minimum cable length of 50 feet to limit maximum fault currents and prevent damage to the power circuits within the unit.

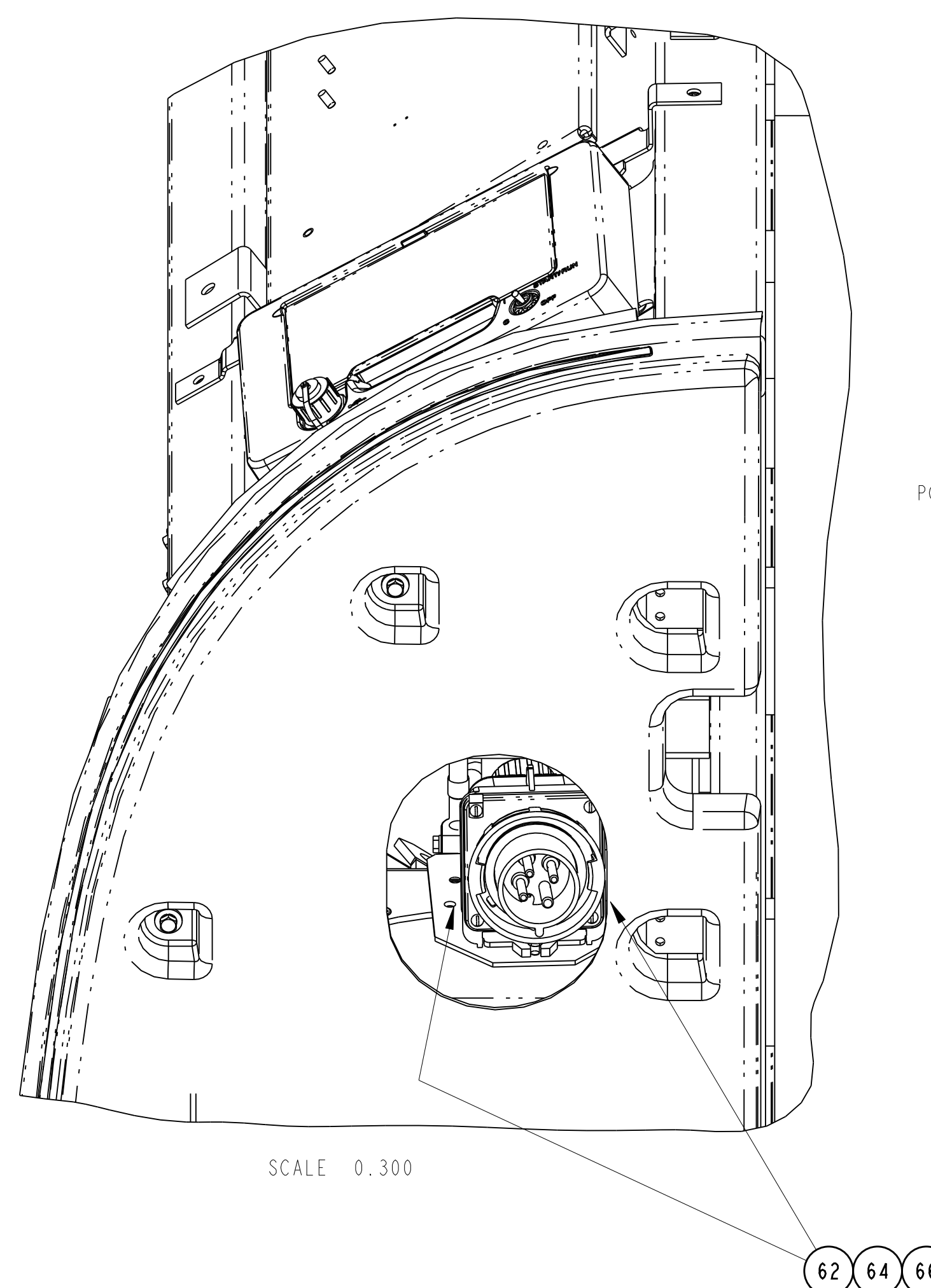

PARTIAL LOWER  
ROADSIDE VIEW  
STANDBY PLUG MOUNTING

### CUSTOMER CABLE AND PLUG ASSEMBLY

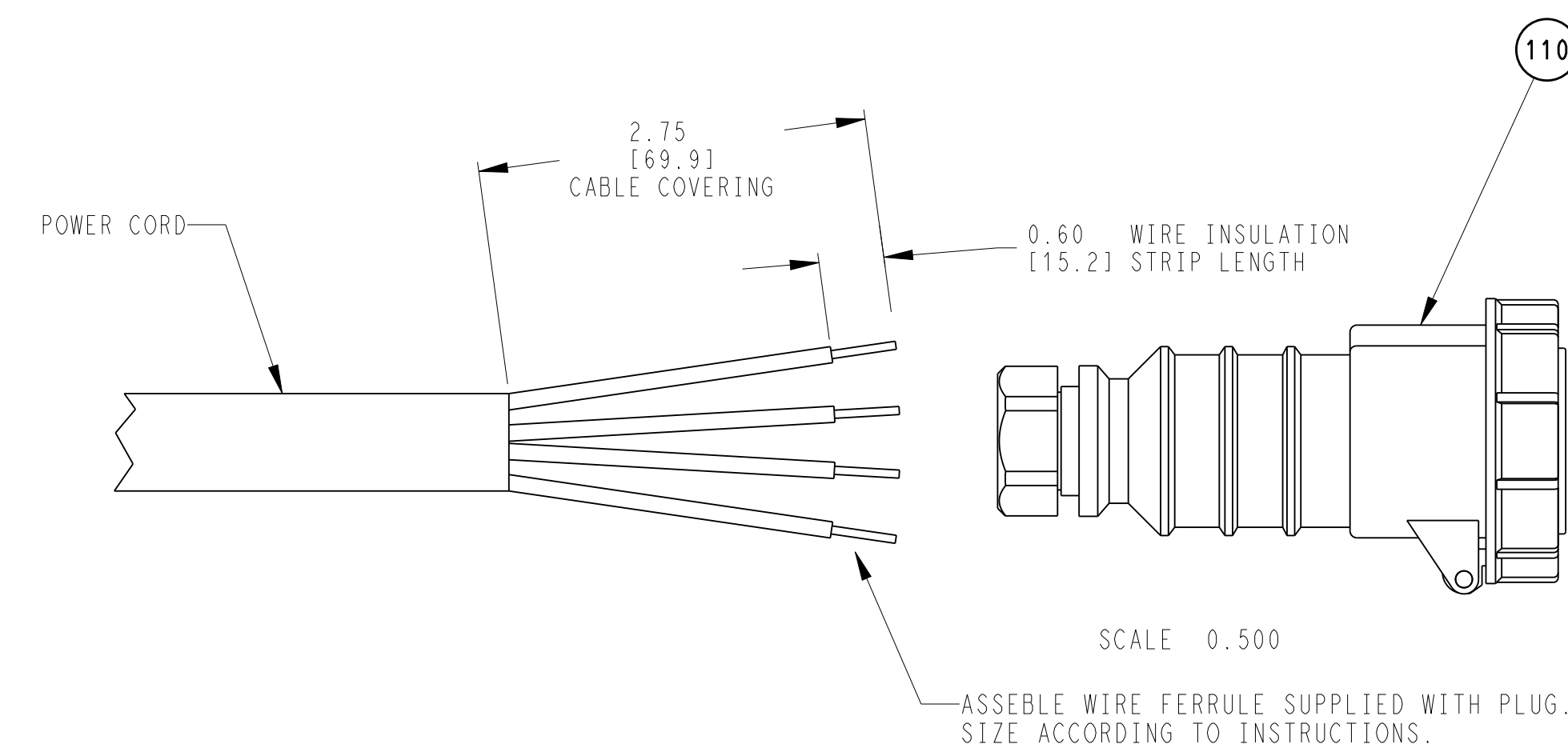

## WARNING:

BE SURE POWER IS DIS-CONNECTED TO CUSTOMER CABLE.  
READ ENTIRE SUPPLIER DIRECTIONS SUPPLIED WITH PLUG BEFORE STARTING INSTALLATION.



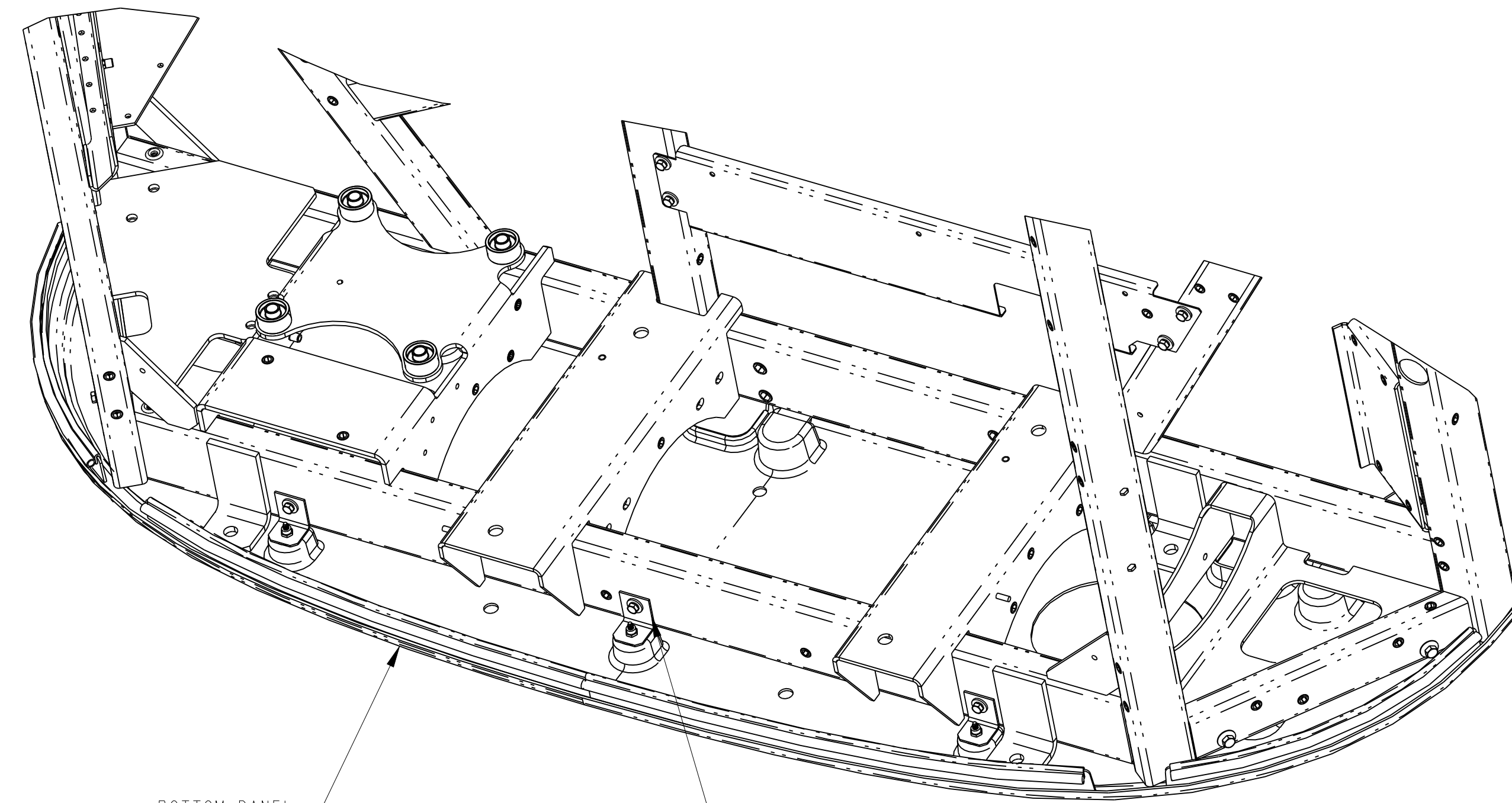

BOTTOM PANEL

75 80  
 3 3

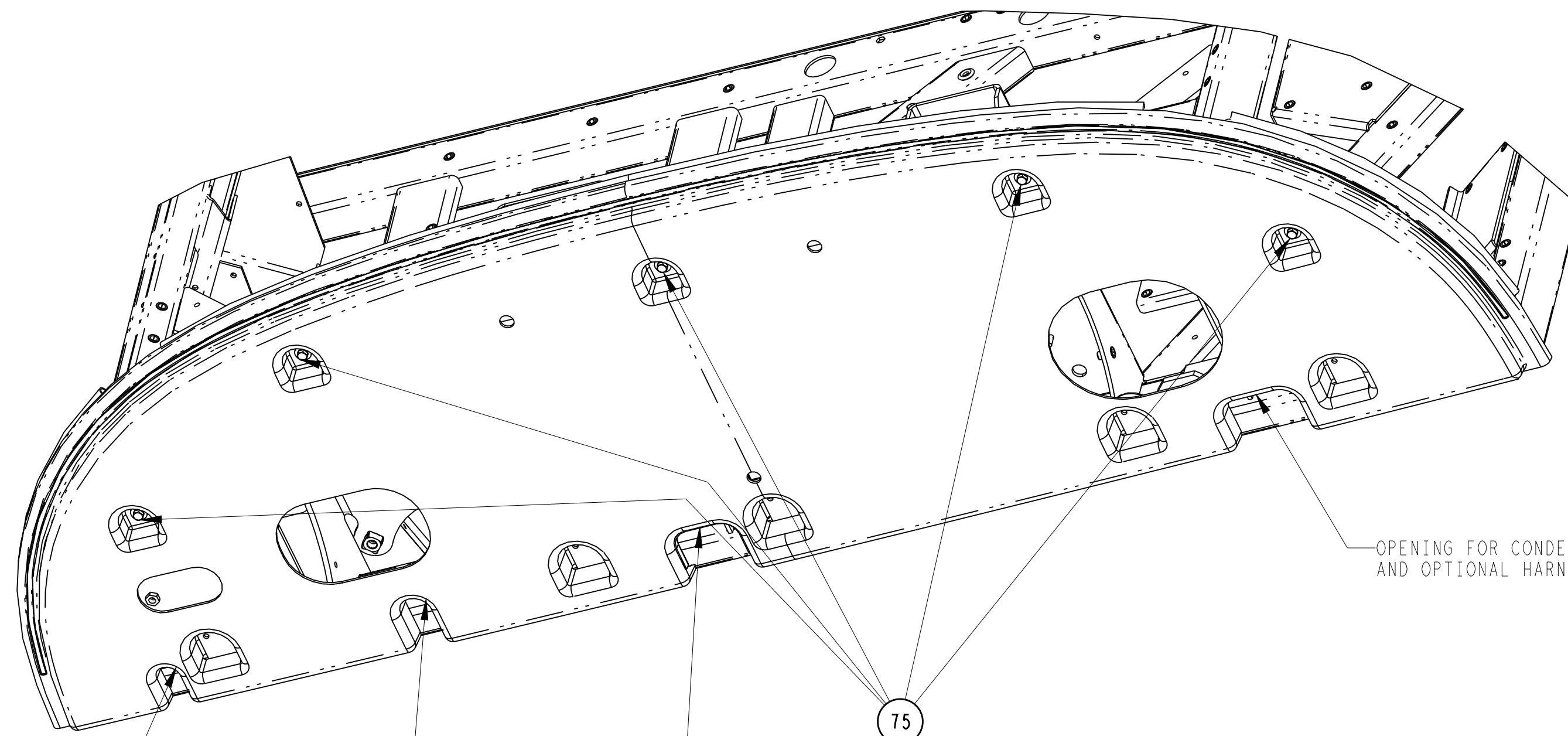

OPENING FOR CONDENSATE DRAIN LINE

OPENING LIFT GATE BATTERY CABLE OPTION

OPENING FOR FUEL LINE ROUTING

OPENING FOR CONDENSATE DRAIN LINE AND OPTIONAL HARNESS CONNECTORS.

75

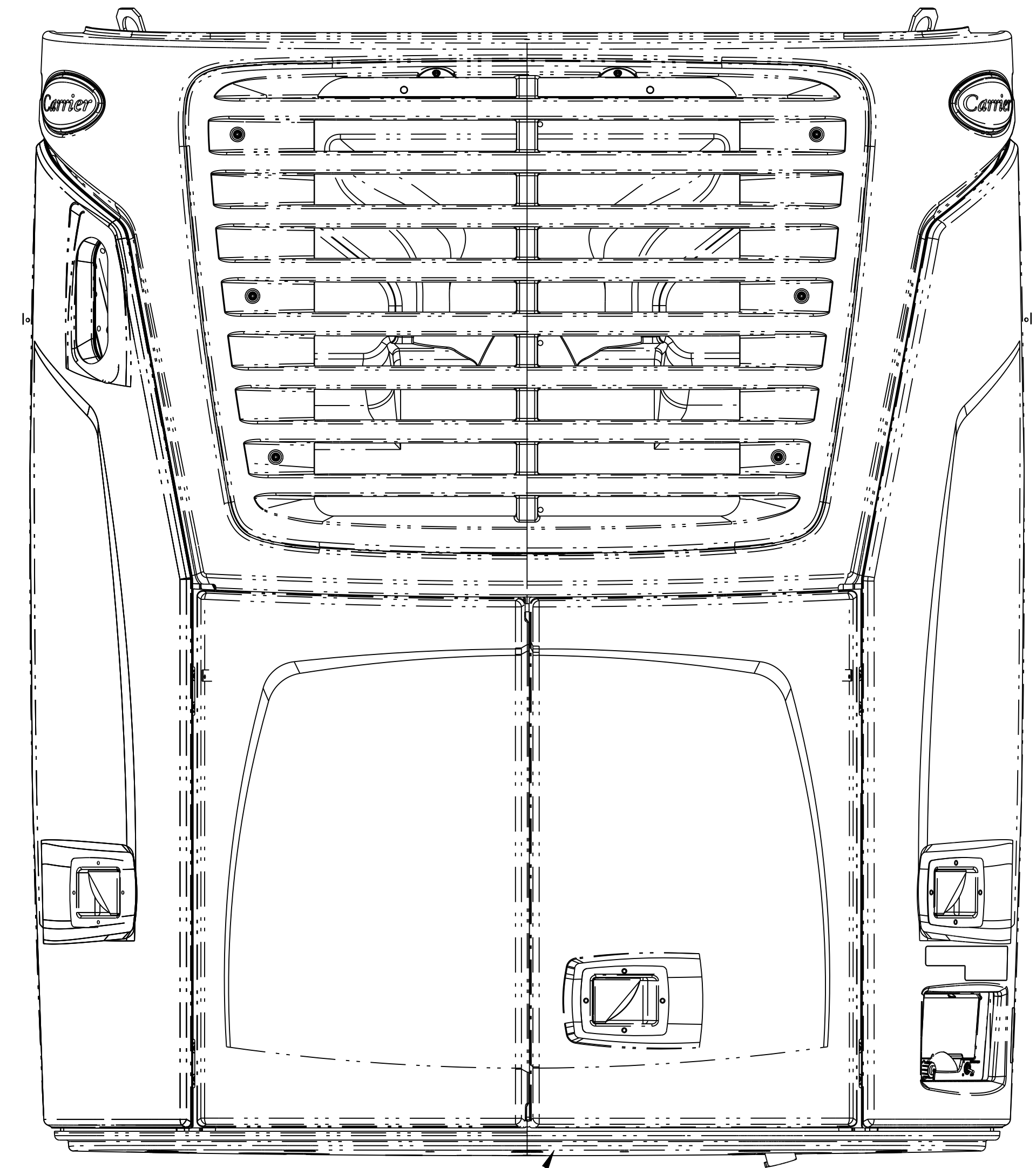

BOTTOM PANEL (REF)

## BOTTOM PANEL INSTALLATION

NOTES:

- 1.0 INSTALL (3) MOUNTING ANGLES (ITEM #80), WITH RIVNUTED FLANGE DOWN, TO FRAME USING SUPPLIED SCREWS (ITEM #75). TORQUE SCREW TO 96 IN-LBS, KEEPING THE BOTTOM OF THE ANGLES FLUSH AND PARALLEL TO THE BOTTOM OF THE FRAME.
- 2.0 SLIDE (5) OPENINGS IN THE BOTTOM PANEL OVER THE (5) REAR MOUNTING ANGLES ON THE FRAME AND SECURE BOTTOM PANEL TO OTHER (5) MOUNTING ANGLES USING SUPPLIED SCREWS (ITEM #75). TORQUE SCREWS SECURELY TO 96 IN-LBS.

C	NEW SHEET.	28 MAR 2017	ZMG			72N0217P17
SYM	REVISION RECORD	DATE	BY	ENGR.	M.E.	NPCA NO.

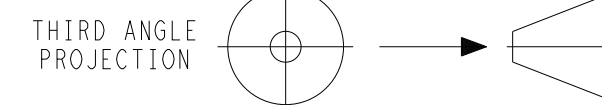

IMPERIAL INCH FORMAT:  
 UNLESS OTHERWISE SPECIFIED  
 DIMENSIONS ARE IN INCHES WITH  
 METRIC CONVERSIONS IN [MILLIMETERS]

TITLE  
 INSTALLATION INSTRUCTIONS  
 TRAILERS: 2 & 3 COMPARTMENT MULTI-TEMP VECTOR 8600MT

DRAWING NO. 98-02593  
 SHEET 9 OF C

SUPERSEDES:

PART CLASSIFICATION: US EAR99